

LISTINO PREZZI.

2
0
2
2

PRICE LIST 2022
LISTE DES PRIX 2022



KARMEK ONE



Q u a n d o c e r c h i i l c a l o r e . . . C e r c h i

LEGENDA

Legend

Légende

A+

CLASSE EFFICIENZA ENERGETICA - La classe di efficienza energetica indica il livello di efficienza del prodotto secondo gli standard Europei.

ENERGY EFFICIENCY CLASS - The energy efficiency class indicates the efficiency level of the product according to European standards.

CLASSE D'EFFICACITÀ ENERGETIQUE - La classe d'efficacité énergétique indique le niveau d'efficacité du produit selon les normes européennes.

BRACIERE AUTOPULENTE - Il braciere autopulente è un braciere dotato di un fondo a dischi rotanti che consente di scaricare automaticamente la cenere



SELF-CLEANING BRAZIER - The self-cleaning brazier is a brazier equipped with a bottom with rotating discs that allows you to download automatically the ash

BRASIER AUTO-NETTOYANT - Le brasier autonettoyant est un brasier équipé d'un fond avec des disques rotatifs qui vous permet de télécharger automatiquement la cendre

CANALIZZAZIONE

La canalizzazione consente di impiegare la stufa a pellet come un completo impianto di riscaldamento. È possibile canalizzare il flusso di aria calda anche in spazi lontani dalla stufa o su piani diversi, con la sicurezza di ottenere sempre lo stesso comfort dell'ambiente di installazione. Tale sistema permette di convogliare l'aria calda attraverso condotti flessibili, opportunamente coibentati e facilmente installabili. L'aria calda defluisce al livello del suolo e può essere regolata tramite l'utilizzo di apposite bocchette.

CANALIZATION

The channeling allows you to use the pellet stove as a complete heating system. It is possible to channel the air flow hot even in spaces far from the stove or on different floors, with security to always get the same comfort of the installation environment. This system allows to convey hot air through flexible ducts, suitably insulated and easily installable. The hot air flows to the ground level and can be adjusted through use of special vents.

CANALISATION

La canalisation vous permet de utiliser le poêle à granulés comme système de chauffage complet. Il est possible de canaliser le flux d'air chaud même dans les espaces éloignés du poêle ou à différents étages, avec sécurité pour toujours avoir le même confort de l'environnement d'installation. Ce système permet de véhiculer air chaud à travers des conduits flexibles, convenablement isolé et facilement installable. L'air chaud circule au niveau du sol et peut être ajusté par l'utilisation d'évents spéciaux.



VENTILAZIONE - La ventilazione ambiente consente di riscaldare il locale dove risiede la termostufa tramite un flusso di aria calda, in maniera simile a quanto possibile con le stufe a pellet.



VENTILATION - Room ventilation allows to heat the room where the thermo stove through a flow of air hot, similar to how much possible with pellet stoves.

VENTILATION - La ventilation de la pièce permet pour chauffer la pièce où thermo poêle à travers un flux d'air chaud, semblable à combine possible avec des poêles à granulés.

DETRAZIONI FISCALI - Può usufruire del conto termico e delle detrazioni fiscali



TAX DEDUCTIONS - You can take advantage of the thermal account and the tax deductions

DÉDUCTIONS FISCALES - Vous pouvez profiter du compte thermique et du Déductions fiscales



CARICAMENTO ROTATIVO - Permette un'alimentazione combustibile più omogenea

ROTARY LOADING - Allows fuel supply more homogeneous

CHARGEMENT ROTATIF - Permet l'alimentation en carburant plus homogène



MULTI-SYSTEM
MULTI-SYSTEM
MULTI-SYSTEM



CERTIFICAZIONE ACTECO - Prodotto omologato dall'ente di certificazione Acteco
ACTECO CERTIFICATION - Product approved by the Acteco certification body
CERTIFICATION ACTECO - Produit approuvé par l'organisme de certification Acteco



CERTIFICAZIONE KIWA - Prodotto omologato dall'ente di certificazione Kiwa
KIWA CERTIFICATION - Product approved by the Kiwa certification body
CERTIFICATION KIWA - Produit approuvé par l'organisme de certification Kiwa



Modulo Wi-Fi
Module card Wi Fi
Module Wi Fi

INDICE

index

index

Stufe pellet aria

Air pellet stoves Poêles à granulés d'air

ASIA S1	P. 7
BILBAO S1	P. 8
VIGO S1	P. 9
VIGO S1 PLUS	P. 9
IBIZA S	P. 10
LEON S1	P. 11
LEON S1 PLUS	P. 11
VALENCIA S1 PLUS - acciaio	P. 12
VALENCIA S1 PLUS - ceramica	P. 13
MINERVA S1 PLUS - acciaio	P. 14
MINERVA S1 PLUS - ceramica	P. 15
ALICE S1 - acciaio	P. 16
ALICE S1 - vetro	P. 17
ALICE S1 - pietra	P. 18
ALICE S1 - ceramica	P. 19
ALICE S1 CANALIZZATA - acciaio	P. 20
ALICE S1 CANALIZZATA - vetro	P. 21
ALICE S1 CANALIZZATA - pietra	P. 22
ALICE S1 CANALIZZATA - ceramica	P. 23
ECLIPSE PLUS - acciaio	P. 24
ECLIPSE PLUS - vetro	P. 25
ECLIPSE PLUS - serpentino	P. 26
ISCHIA PLUS	P. 27
GIOVE PLUS	P. 28
VENERE PLUS	P. 29
ELBA PLUS - acciaio	P. 30
ELBA PLUS - ceramica	P. 31

Inserti pellet aria

Air pellet inserts Inserts de granulés d'air

BREMA	P. 33
BREMA CANALIZZATO	P. 34
BREMA CAMINO	P. 35
BREMA CAMINO 1	P. 36
AIR FORCE ONE 20 PLUS	P. 37
AIR FORCE ONE 28 PLUS	P. 38

Termostufe hydro ventilate

Hydro-ventilated thermo stoves Thermopoêles hydro-ventilés

BERNA	P. 40
SIVIGLIA S1 - acciaio	P. 41
SIVIGLIA S1 - ceramica	P. 42
LIONE	P. 43
CAPRI - acciaio	P. 44
CAPRI - vetro	P. 45
CAPRI - ceramica	P. 46
AMALFI - acciaio	P. 47
AMALFI - ceramica	P. 48
MADRID	P. 49

Caldaie pellet

Pellet boilers Chaudières à granulés

TERMORODI 22 A	P. 51
TERMORODI 24	P. 52
TERMORODI 34	P. 53
ACCESSORI - ACCESSORIES ACCESSOIRES	P. 55

- 
- STUFE PELLET ARIA
 - AIR PELLET STOVES
 - POÊLES À GRANULÉS D'AIR

ASIA S1



Versioni e colori - Versions and colors - Versions et couleurs



C4000
Rosso
Red
Rouge

€ 1.362,00



C4001
Bianco
White
Blanc

€ 1.362,00



C4002
Antracite
Anthracite
Anthracite

€ 1.362,00

Accessori - Accessories - Accessoires



SML510-00AC

Telecomando opzionale
Remote control available as an option
Télécommande en option

€ 28,00

Stufe pellet aria
Air pellet stoves
Poêles à granulés d'air

A+



Dati tecnici - Technical data - Données techniques

MISURE (H X L X P)
DIMENSIONS (H X L X P)
DIMENSIONS (H X L X P)

84 X 45 X 52 cm

POTENZA TERMOCHIMICA
THERMO-CHEMICAL POWER
PUISSANCE THERMOCHIMIQUE

7,11 kW

POTENZA NOMINALE
RATED OUTPUT
PUISSANCE NOMINALE

6,3 kW

RENDIMENTO A POTENZA MIN/MAX
MIN/MAX EFFICIENCY
RENDEMENT MIN/MAX

94,39 - 88,50 %

CLASSE DI EFFICIENZA ENERGETICA
ENERGY EFFICIENCY CLASS
CLASSE D'EFFICACITÀ ÉNERGÉTIQUE

A+

CONFORME ALLE NORME
IN CONFORMITY TO STANDARD
CONFORME AUX RÉGLES

UNI-EN 14785

VOLUME RISCALDABILE MAX
MAX HEATABLE VOLUME
VOLUME CHAUFFABLE MAX

180 m³

CONSUMO ORARIO MIN/MAX
MIN/MAX CONSUMPTION
CONSOMMATION MIN/MAX

0,92 - 1,47 kg/h

ALIMENTAZIONE ELETTRICA
TENSION - FREQUENCY
TENSION - FRÉQUENCE

230 V - 50 Hz

ASSORBIMENTO ELETTRICO NOMINALE
RATED POWER CONSUMPTION
CONSOMMATION ÉLECTRIQUE NOMINALE

60 W

CAPACITÀ SERBATOIO
RESERVOIR CAPACITY
CAPACITÉ DU RESERVOIR

11 Kg

DIAMETRO SCARICO FUMI
SMOKE OUTLET DIAMETER
DIAMÈTRE SORTIE DES FUMÉES

80 mm

PESO (CON IMBALLO)
WEIGHT (INCLUDING PACKAGE)
POIDS (AVEC EMBALLAGE)

77 Kg

Caratteristiche particolari

- Scarico fumi posteriore
- Braciere in ghisa

Characteristics

- Rear Smoke outlet
- Cast iron brazier

Caractéristique

- Sortie des fumées arrière
- Creuset en fonte

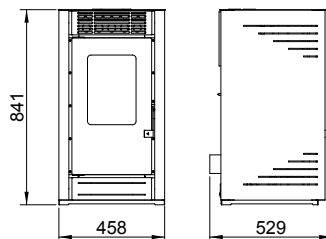

BILBAO S1



Versioni e colori - Versions and colors - Versions et couleurs



S1000
Rosso
Red
Rouge

€ 1.717,00



S1001
Bianco
White
Blanc

€ 1.717,00



S1002
Nero
Black
Noir

€ 1.717,00

Accessori - Accessories - Accessoires



SML510-00AC

Telecomando opzionale
Remote control available as an option
Télécommande en option

€ 28,00



Stufe pellet aria
Air pellet stoves
Poêles à granulés d'air

A+



Dati tecnici - Technical data - Données techniques

MISURE (H X L X P)
DIMENSIONS (H X L X P)
DIMENSIONS (H X L X P)

95 x 49 x 53 cm

POTENZA TERMOCHIMICA
THERMO-CHEMICAL POWER
PUISSANCE THERMOCHIMIQUE

9,55 kW

POTENZA NOMINALE
RATED OUTPUT
PUISSANCE NOMINALE

8,33 kW

RENDIMENTO A POTENZA MIN/MAX
MIN/MAX EFFICIENCY
RENDEMENT MIN/MAX

94,39 - 87,22 %

CLASSE DI EFFICIENZA ENERGETICA
ENERGY EFFICIENCY CLASS
CLASSE D'EFFICACITÀ ENERGÉTIQUE

A+

CONFORME ALLE NORME
IN CONFORMITY TO STANDARD
CONFORME AUX RÈGLES

UNI-EN 14785

VOLUME RISCALDABILE MAX
MAX HEATABLE VOLUME
VOLUME CHAUFFABLE MAX

238 m³

CONSUMO ORARIO MIN/MAX
MIN/MAX CONSUMPTION
CONSOMMATION MIN/MAX

0,92 - 1,97 kg/h

ALIMENTAZIONE ELETTRICA
TENSION - FREQUENCY
TENSION - FRÉQUENCE

230 V - 50 Hz

ASSORBIMENTO ELETTRICO NOMINALE
RATED POWER CONSUMPTION
CONSOMMATION ÉLECTRIQUE NOMINALE

81,8 W

CAPACITÀ SERBATOIO
RESERVOIR CAPACITY
CAPACITÉ DU RESERVOIR

17 Kg

DIAMETRO SCARICO FUMI
SMOKE OUTLET DIAMETER
DIAMÈTRE SORTIE DES FUMÉES

80 mm

PESO (CON IMBALLO)
WEIGHT (INCLUDING PACKAGE)
POIDS (AVEC EMBALLAGE)

101 Kg

Caratteristiche particolari

- Scarico fumi posteriore
- Cassetto cenere estraibile
- Braciata in ghisa

Characteristics

- Rear Smoke outlet
- Removable ash pan
- Cast iron brazier

Caractéristique

- Sortie des fumées arrière
- Tiroir à cendres amovible
- Creuset en fonte

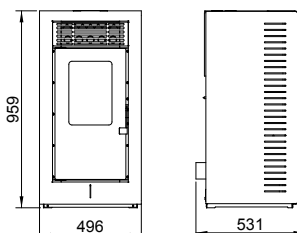



VIGO S1

VIGO S1 PLUS

Versioni e colori - Versions and colors - Versions et couleurs



Rosso
Red
Rouge



Bianco
White
Blanc



Nero
Black
Noir



Bronzo
Bronze

VIGO S1	S2000 - € 1.871,00	S2001 - € 1.871,00	S2002 - € 1.871,00	S2003 - € 1.871,00
VIGO S1 PLUS	S2000P - € 2.060,00	S2001P - € 2.060,00	S2002P - € 2.060,00	S2003P - € 2.060,00

Accessori - Accessories - Accessoires



K1093

Modulo Wi-Fi opzionale (solo per versione PLUS)
Module card Wi Fi available as an option (only for version PLUS)
Module Wi Fi en option (seulement pour la version PLUS)

€ 290,00



AC1003

Kit canalizzazione opzionale (solo per versione PLUS)
Ducting Kit (available as an option only for version PLUS)
Kit de canalisation optionnel (seulement pour la version PLUS)

€ 350,00

Stufe pellet aria
Air pellet stoves
Poêles à granulés d'air



Dati tecnici - Technical data - Données techniques

MISURE (H X L X P) DIMENSIONS (H X L X P) DIMENSIONS (H X L X P)	100 x 49 x 56 cm
POTENZA TERMOCHIMICA THERMO-CHEMICAL POWER PUISSANCE THERMOCHIMIQUE	11,67 kW
POTENZA NOMINALE RATED OUTPUT PUISSANCE NOMINALE	10,28 kW
RENDIMENTO A POTENZA MIN/MAX MIN/MAX EFFICIENCY RENDEMENT MIN/MAX	93,07 - 88,09 %
CLASSE DI EFFICIENZA ENERGETICA ENERGY EFFICIENCY CLASS CLASSE D'EFFICACITÉ ÉNERGÉTIQUE	A+
CONFORME ALLE NORME IN CONFORMITY TO STANDARD CONFORME AUX RÈGLES	UNI-EN 14785
VOLUME RISCALDABILE MAX MAX HEATABLE VOLUME VOLUME CHAUFFABLE MAX	294 m ³
CONSUMO ORARIO MIN/MAX MIN/MAX CONSUMPTION CONSOMMATION MIN/MAX	1,00 - 2,41 kg/h
ALIMENTAZIONE ELETTRICA TENSION - FREQUENCY TENSION - FRÉQUENCE	230 V - 50 Hz
ASSORBIMENTO ELETTRICO NOMINALE RATED POWER CONSUMPTION CONSOMMATION ÉLECTRIQUE NOMINALE	86 W
CAPACITÀ SERBATOIO RESERVOIR CAPACITY CAPACITÉ DU RESERVOIR	18,5 Kg
DIAMETRO SCARICO FUMI SMOKE OUTLET DIAMETER DIAMÈTRE SORTIE DES FUMÉES	80 mm
PESO (CON IMBALLO) WEIGHT (INCLUDING PACKAGE) POIDS (AVEC EMBALLAGE)	104 Kg

Caratteristiche particolari

- Telecomando di serie
- Scarico fumi posteriore
- Cassetto cenere estraibile
- Braciore in ghisa
- Sistema di pulizia automatica del braciore (versione PLUS)

Characteristics

- Remote control included
- Rear Smoke outlet
- Removable ash pan
- Cast iron brazier
- Automatic cleaning system of the brazier (version PLUS)

Caractéristique

- Télécommande (incluse)
- Sortie des fumées arrière
- Tiroir à cendres amovible
- Creuset en fonte
- Système autonettoyant du creuset (version PLUS)

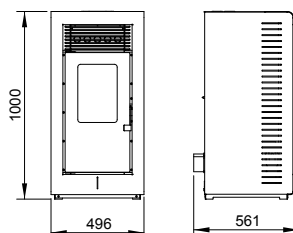

IBIZA S



Versioni e colori - Versions and colors - Versions et couleurs



S4000
Rosso
Red
Rouge

€ 2.025,00



S4001
Bianco
White
Blanc

€ 2.025,00



S4002
Nero
Black
Noir

€ 2.025,00

Accessori - Accessories - Accessoires



AC1002

Kit canalizzazione opzionale
Ducting Kit available as an option
Kit de canalisation optionnel

€ 350,00



Stufe pellet aria
Air pellet stoves
Poêles à granulés d'air

A+



Dati tecnici - Technical data - Données techniques

MISURE (H X L X P) DIMENSIONS (H X L X P) DIMENSIONS (H X L X P)	104 x 79 x 39 cm
POTENZA TERMOCHIMICA THERMO-CHEMICAL POWER PUISSANCE THERMOCHIMIQUE	10,57 kW
POTENZA NOMINALE RATED OUTPUT PUISSANCE NOMINALE	9,54 kW
RENDIMENTO A POTENZA MIN/MAX MIN/MAX EFFICIENCY RENDMENT MIN/MAX	93,86 - 90,26 %
CLASSE DI EFFICIENZA ENERGETICA ENERGY EFFICIENCY CLASS CLASSE D'EFFICACITÉ ÉNERGÉTIQUE	A+
CONFORME ALLE NORME IN CONFORMITY TO STANDARD CONFORME AUX RÉGLES	UNI-EN 14785
VOLUME RISCALDABILE MAX MAX HEATABLE VOLUME VOLUME CHAUFFABLE MAX	273 m ³
CONSUMO ORARIO MIN/MAX MIN/MAX CONSUMPTION CONSOMMATION MIN/MAX	0,97 - 2,19 kg/h
ALIMENTAZIONE ELETTRICA TENSION - FREQUENCY TENSION - FRÉQUENCE	230 V - 50 Hz
ASSORBIMENTO ELETTRICO NOMINALE RATED POWER CONSUMPTION CONSOMMATION ÉLECTRIQUE NOMINALE	108 W
CAPACITÀ SERBATOIO RESERVOIR CAPACITY CAPACITÉ DU RESERVOIR	15 Kg
DIAMETRO SCARICO FUMI SMOKE OUTLET DIAMETER DIAMÈTRE SORTIE DES FUMÉES	80 mm
PESO (CON IMBALLO) WEIGHT (INCLUDING PACKAGE) POIDS (AVEC EMBALLAGE)	111 Kg

Caratteristiche particolari

- Telecomando di serie
- Scarico fumi posteriore, laterale e superiore
- Cassetto cenere estraibile
- Braciere in ghisa

Characteristics

- Remote control included
- Upper, Rear and lateral Smoke outlet
- Removable ash pan
- Cast iron brazier

Caractéristique

- Télécommande (incluse)
- Sortie des fumées supérieure, latérale et arrière
- Tiroir à cendres amovible
- Creuset en fonte

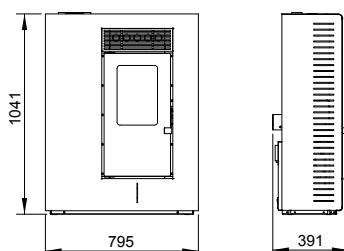

LEON S1

LEON S1 PLUS



Versioni e colori - Versions and colors - Versions et couleurs



Rosso
Red
Rouge



Bianco
White
Blanc



Nero
Black
Noir



Bronzo
Bronze
Bronze

LEON S1

S3000 - € 2.278,00

S3001 - € 2.278,00

S3002 - € 2.278,00

S3003 - € 2.278,00

LEON S1 PLUS

S3000P - € 2.529,00

S3001P - € 2.529,00

S3002P - € 2.529,00

S3003P - € 2.529,00

Accessori - Accessories - Accessoires



K1093

Modulo Wi-Fi opzionale (solo per versione PLUS)
Module card Wi Fi available as an option (only for version PLUS)
Module Wi Fi en option (seulement pour la version PLUS)

€ 290,00



AC1003

Kit canalizzazione opzionale (solo per versione PLUS)
Ducting Kit (available as an option only for version PLUS)
Kit de canalisation optionnel (seulement pour la version PLUS)

€ 350,00

Stufe pellet aria
Air pellet stoves
Poêles à granulés d'air



Dati tecnici - Technical data - Données techniques

MISURE (H X L X P)
DIMENSIONS (H X L X P)
DIMENSIONS (H X L X P)

103 x 49 x 56 cm

POTENZA TERMOCHIMICA
THERMO-CHEMICAL POWER
PUISSANCE THERMOCHIMIQUE

13,22 kW

POTENZA NOMINALE
RATED OUTPUT
PUISSANCE NOMINALE

11,52 kW

RENDIMENTO A POTENZA MIN/MAX
MIN/MAX EFFICIENCY
RENDEMENT MIN/MAX

93,07 - 87,15 %

CLASSE DI EFFICIENZA ENERGETICA
ENERGY EFFICIENCY CLASS
CLASSE D'EFFICACITÀ ÉNERGÉTIQUE

A+

CONFORME ALLE NORME
IN CONFORMITY TO STANDARD
CONFORME AUX RÈGLES

UNI-EN 14785

VOLUME RISCALDABILE MAX
MAX HEATABLE VOLUME
VOLUME CHAUFFABLE MAX

330 m³

CONSUMO ORARIO MIN/MAX
MIN/MAX CONSUMPTION
CONSUMMATION MIN/MAX

1,00 - 2,73 kg/h

ALIMENTAZIONE ELETTRICA
TENSION - FREQUENCY
TENSION - FRÉQUENCE

230 V - 50 Hz

ASSORBIMENTO ELETTRICO NOMINALE
RATED POWER CONSUMPTION
CONSUMMATION ÉLECTRIQUE NOMINALE

91 W

CAPACITÀ SERBATOIO
RESERVOIR CAPACITY
CAPACITÉ DU RESERVOIR

20 Kg

DIAMETRO SCARICO FUMI
SMOKE OUTLET DIAMETER
DIAMÈTRE SORTIE DES FUMÉES

80 mm

PESO (CON IMBALLO)
WEIGHT (INCLUDING PACKAGE)
POIDS (AVEC EMBALLAGE)

112 Kg

Caratteristiche particolari

- Telecomando di serie
- Scarico fumi posteriore
- Cassetto cenere estraibile
- Braciore in ghisa
- Sistema di pulizia automatica del braciore (versione PLUS)

Characteristics

- Remote control included
- Rear Smoke outlet
- Removable ash pan
- Cast iron brazier
- Automatic cleaning system of the brazier (version PLUS)

Caractéristique

- Télécommande (incluse)
- Sortie des fumées arrière
- Tiroir à cendres amovible
- Creuset en fonte
- Système autonettoyant du creuset (version PLUS)

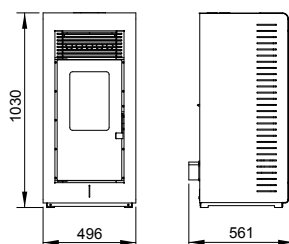

VALENCIA S1 PLUS ACCIAIO ★ ★ ★ ★



Versioni e colori - Versions and colors - Versions et couleurs



N7050P

Rosso
Red
Rouge

€ 2.838,00



N7051P

Bianco
White
Blanc

€ 2.838,00

Accessori - Accessories - Accessoires



K1093

Modulo Wi-Fi opzionale
Module card Wi Fi available as an option
Module Wi Fi en option

€ 290,00



Stufe pellet aria
Air pellet stoves
Poêles à granulés d'air

A+



Dati tecnici - Technical data - Données techniques

MISURE (H X L X P)
DIMENSIONS (H X L X P)
DIMENSIONS (H X L X P)

101 x 60 x 55 cm

POTENZA TERMOCHIMICA
THERMO-CHEMICAL POWER
PUISSANCE THERMOCHIMIQUE

13,22 kW

POTENZA NOMINALE
RATED OUTPUT
PUISSANCE NOMINALE

11,52 kW

RENDIMENTO A POTENZA MIN/MAX
MIN/MAX EFFICIENCY
RENDEMENT MIN/MAX

93,07 - 87,15 %

CLASSE DI EFFICIENZA ENERGETICA
ENERGY EFFICIENCY CLASS
CLASSE D'EFFICACITÉ ÉNERGÉTIQUE

A+

CONFORME ALLE NORME
IN CONFORMITY TO STANDARD
CONFORME AUX RÉGLES

UNI-EN 14785

VOLUME RISCALDABILE MAX
MAX HEATABLE VOLUME
VOLUME CHAUFFABLE MAX

330 m³

CONSUMO ORARIO MIN/MAX
MIN/MAX CONSUMPTION
CONSOMMATION MIN/MAX

1,00 - 2,73 kg/h

ALIMENTAZIONE ELETTRICA
TENSION - FREQUENCY
TENSION - FRÉQUENCE

230 V - 50 Hz

ASSORBIMENTO ELETTRICO NOMINALE
RATED POWER CONSUMPTION
CONSOMMATION ÉLECTRIQUE NOMINALE

91 W

CAPACITÀ SERBATOIO
RESERVOIR CAPACITY
CAPACITÉ DU RESERVOIR

15 Kg

DIAMETRO SCARICO FUMI
SMOKE OUTLET DIAMETER
DIAMÈTRE SORTIE DES FUMÉES

80 mm

PESO (CON IMBALLO)
WEIGHT (INCLUDING PACKAGE)
POIDS (AVEC EMBALLAGE)

152 Kg

Caratteristiche particolari

- Telecomando di serie
- Scarico fumi posteriore
- Cassetto cenere estraibile
- Braciere, porta e frontalino in ghisa
- Sistema di pulizia automatica del braciere

Characteristics

- Remote control included
- Rear Smoke outlet
- Removable ash pan
- Cast iron brazier, hot air grate and door
- Automatic cleaning system of the brazier

Caractéristique

- Télécommande (incluse)
- Sortie des fumées arrière
- Tiroir à cendres amovible
- Creuset, grille et porte en fonte
- Systeme autonettoyant du creuset

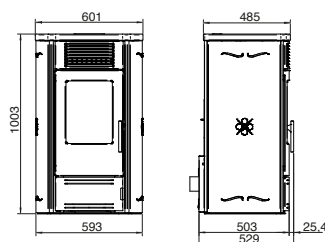

VALENCIA S1 PLUS CERAMICA ☆☆☆☆



Versioni e colori - Versions and colors - Versions et couleurs



N7000P

Rosso
Red
Rouge

€ 3.205,00



N7001P

Bianco
White
Blanc

€ 3.205,00

Accessori - Accessories - Accessoires



K1093

Modulo Wi-Fi opzionale
Module card Wi Fi available as an option
Module Wi Fi en option

€ 290,00

Stufe pellet aria
Air pellet stoves
Poêles à granulés d'air

A+



Dati tecnici - Technical data - Données techniques

MISURE (H X L X P)
DIMENSIONS (H X L X P)
DIMENSIONS (H X L X P)

101 x 60 x 55 cm

POTENZA TERMOCHIMICA
THERMO-CHEMICAL POWER
PUISSANCE THERMOCHIMIQUE

13,22 kW

POTENZA NOMINALE
RATED OUTPUT
PUISSANCE NOMINALE

11,52 kW

RENDIMENTO A POTENZA MIN/MAX
MIN/MAX EFFICIENCY
RENDMENT MIN/MAX

93,07 - 87,15 %

CLASSE DI EFFICIENZA ENERGETICA
ENERGY EFFICIENCY CLASS
CLASSE D'EFFICACITÉ ÉNERGÉTIQUE

A+

CONFORME ALLE NORME
IN CONFORMITY TO STANDARD
CONFORME AUX RÉGLES

UNI-EN 14785

VOLUME RISCALDABILE MAX
MAX HEATABLE VOLUME
VOLUME CHAUFFABLE MAX

330 m³

CONSUMO ORARIO MIN/MAX
MIN/MAX CONSUMPTION
CONSOMMATION MIN/MAX

1,00 - 2,73 kg/h

ALIMENTAZIONE ELETTRICA
TENSION - FREQUENCY
TENSION - FRÉQUENCE

230 V - 50 Hz

ASSORBIMENTO ELETTRICO NOMINALE
RATED POWER CONSUMPTION
CONSOMMATION ÉLECTRIQUE NOMINALE

91 W

CAPACITÀ SERBATOIO
RESERVOIR CAPACITY
CAPACITÉ DU RESERVOIR

15 Kg

DIAMETRO SCARICO FUMI
SMOKE OUTLET DIAMETER
DIAMÈTRE SORTIE DES FUMÉES

80 mm

PESO (CON IMBALLO)
WEIGHT (INCLUDING PACKAGE)
POIDS (AVEC EMBALLAGE)

162 Kg

Caratteristiche particolari

- Telecomando di serie
- Scarico fumi posteriore
- Cassetto cenere estraibile
- Braciere, porta e frontalino in ghisa
- Sistema di pulizia automatica del braciere

Characteristics

- Remote control included
- Rear Smoke outlet
- Removable ash pan
- Cast iron brazier, hot air grate and door
- Automatic cleaning system of the brazier

Caractéristique

- Télécommande (incluse)
- Sortie des fumées arrière
- Tiroir à cendres amovible
- Creuset, grille et porte en fonte
- Systeme autonettoyant du creuset

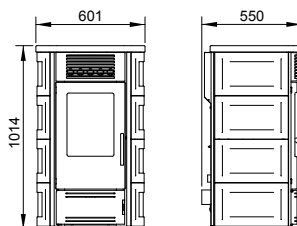

MINERVA S1 PLUS ACCIAIO ☆☆☆☆



Versioni e colori - Versions and colors - Versions et couleurs



P5000
Rosso
Red
Rouge

€ 3.514,00



P5001
Bianco
White
Blanc

€ 3.514,00



P5002
Antracite
Anthracite
Anthracite

€ 3.514,00

Accessori - Accessories - Accessoires



K1093

Modulo Wi-Fi opzionale
Module card Wi Fi available as an option
Module Wi Fi en option

€ 290,00



AC1001

Kit canalizzazione opzionale (solo per versione PLUS)
Ducting Kit (available as an option only for version PLUS)
Kit de canalisation optionnel (seulement pour la version PLUS)

€ 350,00



Stufe pellet aria
Air pellet stoves
Poêles à granulés d'air

A+



Dati tecnici - Technical data - Données techniques

MISURE (H X L X P)
DIMENSIONS (H X L X P)
DIMENSIONS (H X L X P)

120 x 56 x 57 cm

POTENZA TERMOCHIMICA
THERMO-CHEMICAL POWER
PUISSANCE THERMOCHIMIQUE

13,22 kW

POTENZA NOMINALE
RATED OUTPUT
PUISSANCE NOMINALE

11,52 kW

RENDIMENTO A POTENZA MIN/MAX
MIN/MAX EFFICIENCY
RENDEMENT MIN/MAX

93,07 - 87,15 %

CLASSE DI EFFICIENZA ENERGETICA
ENERGY EFFICIENCY CLASS
CLASSE D'EFFICACITÉ ÉNERGÉTIQUE

A+

CONFORME ALLE NORME
IN CONFORMITY TO STANDARD
CONFORME AUX RÈGLES

UNI-EN 14785

VOLUME RISCALDABILE MAX
MAX HEATABLE VOLUME
VOLUME CHAUFFABLE MAX

330 m³

CONSUMO ORARIO MIN/MAX
MIN/MAX CONSUMPTION
CONSOMMATION MIN/MAX

1,00 - 2,73 kg/h

ALIMENTAZIONE ELETTRICA
TENSION - FREQUENCY
TENSION - FRÉQUENCE

230 V - 50 Hz

ASSORBIMENTO ELETTRICO NOMINALE
RATED POWER CONSUMPTION
CONSOMMATION ÉLECTRIQUE NOMINALE

91 W

CAPACITÀ SERBATOIO
RESERVOIR CAPACITY
CAPACITÉ DU RESERVOIR

20 Kg

DIAMETRO SCARICO FUMI
SMOKE OUTLET DIAMETER
DIAMÈTRE SORTIE DES FUMÉES

80 mm

PESO (CON IMBALLO)
WEIGHT (INCLUDING PACKAGE)
POIDS (AVEC EMBALLAGE)

136 Kg

Caratteristiche particolari

- Telecomando di serie
- Scarico fumi posteriore
- Cassetto cenere estraibile
- Braciere e porta in ghisa
- Sistema di pulizia automatica del braciere

Characteristics

- Remote control included
- Rear Smoke outlet
- Removable ash pan
- Cast iron brazier and door
- Automatic cleaning system of the brazier

Caractéristique

- Télécommande (incluse)
- Sortie des fumées arrière
- Tiroir à cendres amovible
- Creuset et porte en fonte
- Systeme autonettoyant du creuset

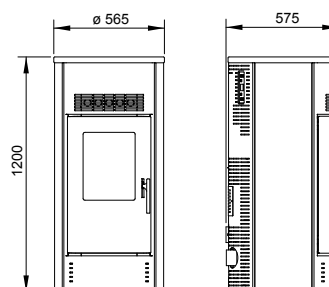

MINERVA S1 PLUS CERAMICA ☆☆☆☆



Versioni e colori - Versions and colors - Versions et couleurs



P5100

Rosso
Red
Rouge

€ 4.224,00



P5101

Bianco
White
Blanc

€ 4.224,00

Accessori - Accessories - Accessoires



K1093

Modulo Wi-Fi opzionale
Module card Wi Fi available as an option
Module Wi Fi en option

€ 290,00



AC1001

Kit canalizzazione opzionale (solo per versione PLUS)
Ducting Kit (available as an option only for version PLUS)
Kit de canalisation optionnel (seulement pour la version PLUS)

€ 350,00

Stufe pellet aria
Air pellet stoves
Poêles à granulés d'air

A+



Dati tecnici - Technical data - Données techniques

MISURE (H X L X P)
DIMENSIONS (H X L X P)
DIMENSIONS (H X L X P)

120 x 56 x 57 cm

POTENZA TERMOCHIMICA
THERMO-CHEMICAL POWER
PUISSANCE THERMOCHIMIQUE

13,22 kW

POTENZA NOMINALE
RATED OUTPUT
PUISSANCE NOMINALE

11,52 kW

RENDIMENTO A POTENZA MIN/MAX
MIN/MAX EFFICIENCY
RENDIMENT MIN/MAX

93,07 - 87,15 %

CLASSE DI EFFICIENZA ENERGETICA
ENERGY EFFICIENCY CLASS
CLASSE D'EFFICACITÉ ÉNERGÉTIQUE

A+

CONFORME ALLE NORME
IN CONFORMITY TO STANDARD
CONFORME AUX RÉGLES

UNI-EN 14785

VOLUME RISCALDABILE MAX
MAX HEATABLE VOLUME
VOLUME CHAUFFABLE MAX

330 m³

CONSUMO ORARIO MIN/MAX
MIN/MAX CONSUMPTION
CONSOMMATION MIN/MAX

1,00 - 2,73 kg/h

ALIMENTAZIONE ELETTRICA
TENSION - FREQUENCY
TENSION - FRÉQUENCE

230 V - 50 Hz

ASSORBIMENTO ELETTRICO NOMINALE
RATED POWER CONSUMPTION
CONSOMMATION ÉLECTRIQUE NOMINALE

91 W

CAPACITÀ SERBATOIO
RESERVOIR CAPACITY
CAPACITÉ DU RESERVOIR

20 Kg

DIAMETRO SCARICO FUMI
SMOKE OUTLET DIAMETER
DIAMÈTRE SORTIE DES FUMÉES

80 mm

PESO (CON IMBALLO)
WEIGHT (INCLUDING PACKAGE)
POIDS (AVEC EMBALLAGE)

149 Kg

Caratteristiche particolari

- Telecomando di serie
- Scarico fumi posteriore
- Cassetto cenere estraibile
- Braciere e porta in ghisa
- Sistema di pulizia automatica del braciere

Characteristics

- Remote control included
- Rear Smoke outlet
- Removable ash pan
- Cast iron brazier and door
- Automatic cleaning system of the brazier

Caractéristique

- Télécommande (incluse)
- Sortie des fumées arrière
- Tiroir à cendres amovible
- Creuset et porte en fonte
- Systeme autonettoyant du creuset

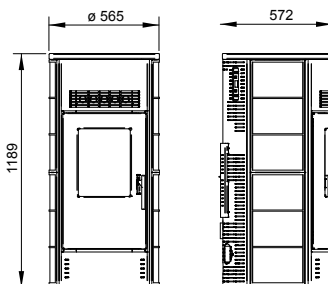

ALICE S1 ACCIAIO ★★☆☆



Versioni e colori - Versions and colors - Versions et couleurs



E7000DV

Rosso
Red
Rouge

€ 2.633,00



E7001DV

Beige
Beige
Beige

€ 2.633,00



E7005DV

Bianco
White
Blanc

€ 2.633,00



Stufe pellet aria
Air pellet stoves
Poêles à granulés d'air

A+



Dati tecnici - Technical data - Données techniques

MISURE (H X L X P) DIMENSIONS (H X L X P) DIMENSIONS (H X L X P)	107 x 87 x 35 cm
POTENZA TERMOCHIMICA THERMO-CHEMICAL POWER PUISSANCE THERMOCHIMIQUE	14,10 kW
POTENZA NOMINALE RATED OUTPUT PUISSANCE NOMINALE	12,68 kW
RENDIMENTO A POTENZA MIN/MAX MIN/MAX EFFICIENCY RENDEMENT MIN/MAX	95,28 - 89,92 %
CLASSE DI EFFICIENZA ENERGETICA ENERGY EFFICIENCY CLASS CLASSE D'EFFICACITÉ ÉNERGÉTIQUE	A+
CONFORME ALLE NORME IN CONFORMITY TO STANDARD CONFORME AUX RÉGLES	UNI-EN 14785
VOLUME RISCALDABILE MAX MAX HEATABLE VOLUME VOLUME CHAUFFABLE MAX	360 m ³
CONSUMO ORARIO MIN/MAX MIN/MAX CONSUMPTION CONSOMMATION MIN/MAX	1,27 - 2,91 kg/h
ALIMENTAZIONE ELETTRICA TENSION - FREQUENCY TENSION - FRÉQUENCE	230 V - 50 Hz
ASSORBIMENTO ELETTRICO NOMINALE RATED POWER CONSUMPTION CONSOMMATION ÉLECTRIQUE NOMINALE	128,8 W
CAPACITÀ SERBATOIO RESERVOIR CAPACITY CAPACITÉ DU RESERVOIR	23 Kg
DIAMETRO SCARICO FUMI SMOKE OUTLET DIAMETER DIAMÈTRE SORTIE DES FUMÉES	80 mm
PESO (CON IMBALLIO) WEIGHT (INCLUDING PACKAGE) POIDS (AVEC EMBALLAGE)	142 Kg

Caratteristiche particolari

- Telecomando di serie
- Scarico fumi superiore, posteriore
- Cassetto cenere estraibile
- Braciare in ghisa
- Porta doppio vetro

Characteristics

- Remote control included
- Upper and rear Smoke outlet
- Removable ash pan
- Cast iron brazier
- Double glass door

Caractéristique

- Télécommande (incluse)
- Sortie des fumées supérieure et arrière
- Tiroir à cendres amovible
- Creuset en fonte
- Porte avec double vitrage

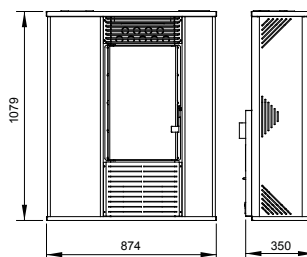

ALICE S1 VETRO ★★★★



Versioni e colori - Versions and colors - Versions et couleurs



E7010DV

Rosso
Red
Rouge

€ 2.930,00



E7011DV

Bianco
White
Blanc

€ 2.930,00



E7012DV

Nero
Black
Noir

€ 2.930,00

Stufe pellet aria
Air pellet stoves
Poêles à granulés d'air

A+



Dati tecnici - Technical data - Données techniques

MISURE (H X L X P) DIMENSIONS (H X L X P) DIMENSIONS (H X L X P)	107 x 87 x 35 cm
POTENZA TERMOCHIMICA THERMO-CHEMICAL POWER PUISSANCE THERMOCHIMIQUE	14,10 kW
POTENZA NOMINALE RATED OUTPUT PUISSANCE NOMINALE	12,68 kW
RENDIMENTO A POTENZA MIN/MAX MIN/MAX EFFICIENCY RENDEMENT MIN/MAX	95,28 - 89,92 %
CLASSE DI EFFICIENZA ENERGETICA ENERGY EFFICIENCY CLASS CLASSE D'EFFICACITÉ ÉNERGÉTIQUE	A+
CONFORME ALLE NORME IN CONFORMITY TO STANDARD CONFORME AUX RÈGLES	UNI-EN 14785
VOLUME RISCALDABILE MAX MAX HEATABLE VOLUME VOLUME CHAUFFABLE MAX	360 m ³
CONSUMO ORARIO MIN/MAX MIN/MAX CONSUMPTION CONSOMMATION MIN/MAX	1,27 - 2,91 kg/h
ALIMENTAZIONE ELETTRICA TENSION - FREQUENCY TENSION - FRÉQUENCE	230 V - 50 Hz
ASSORBIMENTO ELETTRICO NOMINALE RATED POWER CONSUMPTION CONSOMMATION ÉLECTRIQUE NOMINALE	128,8 W
CAPACITÀ SERBATOIO RESERVOIR CAPACITY CAPACITÉ DU RESERVOIR	23 Kg
DIAMETRO SCARICO FUMI SMOKE OUTLET DIAMETER DIAMÈTRE SORTIE DES FUMÉES	80 mm
PESO (CON IMBALLO) WEIGHT (INCLUDING PACKAGE) POIDS (AVEC EMBALLAGE)	142 Kg

Caratteristiche particolari

- Telecomando di serie
- Scarico fumi superiore, posteriore
- Cassetto cenere estraibile
- Braciata in ghisa
- Porta doppio vetro

Characteristics

- Remote control included
- Upper and rear Smoke outlet
- Removable ash pan
- Cast iron brazier
- Double glass door

Caractéristique

- Télécommande (incluse)
- Sortie des fumées supérieure et arrière
- Tiroir à cendres amovible
- Creuset en fonte
- Porte avec double vitrage

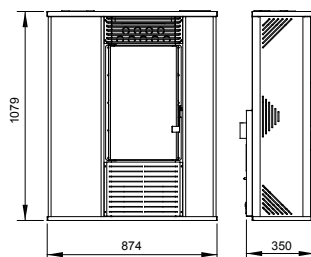

ALICE S1 PIETRA



Versioni e colori - Versions and colors - Versions et couleurs



E7020DV

Ardesia
Slate stone
Ardoise

€ 3.250,00



E7021DV

Pietra Ivory
Ivory stone
Pierre ivoire

€ 3.250,00



Stufe pellet aria
Air pellet stoves
Poêles à granulés d'air

A+



Dati tecnici - Technical data - Données techniques

MISURE (H X L X P) DIMENSIONS (H X L X P) DIMENSIONS (H X L X P)	107 x 87 x 35 cm
POTENZA TERMOCHIMICA THERMO-CHEMICAL POWER PUISSANCE THERMOCHIMIQUE	14,10 kW
POTENZA NOMINALE RATED OUTPUT PUISSANCE NOMINALE	12,68 kW
RENDIMENTO A POTENZA MIN/MAX MIN/MAX EFFICIENCY RENDEMENT MIN/MAX	95,28 - 89,92 %
CLASSE DI EFFICIENZA ENERGETICA ENERGY EFFICIENCY CLASS CLASSE D'EFFICACITÉ ÉNERGÉTIQUE	A+
CONFORME ALLE NORME IN CONFORMITY TO STANDARD CONFORME AUX RÉGLES	UNI-EN 14785
VOLUME RISCALDABILE MAX MAX HEATABLE VOLUME VOLUME CHAUFFABLE MAX	360 m ³
CONSUMO ORARIO MIN/MAX MIN/MAX CONSUMPTION CONSOMMATION MIN/MAX	1,27 - 2,91 kg/h
ALIMENTAZIONE ELETTRICA TENSION - FREQUENCY TENSION - FRÉQUENCE	230 V - 50 Hz
ASSORBIMENTO ELETTRICO NOMINALE RATED POWER CONSUMPTION CONSOMMATION ÉLECTRIQUE NOMINALE	128,8 W
CAPACITÀ SERBATOIO RESERVOIR CAPACITY CAPACITÉ DU RESERVOIR	23 Kg
DIAMETRO SCARICO FUMI SMOKE OUTLET DIAMETER DIAMÈTRE SORTIE DES FUMÉES	80 mm
PESO (CON IMBALLO) WEIGHT (INCLUDING PACKAGE) POIDS (AVEC EMBALLAGE)	142 Kg

Caratteristiche particolari

- Telecomando di serie
- Scarico fumi superiore, posteriore
- Cassetto cenere estraibile
- Braciata in ghisa
- Porta doppio vetro

Characteristics

- Remote control included
- Upper and rear Smoke outlet
- Removable ash pan
- Cast iron brazier
- Double glass door

Caractéristique

- Télécommande (incluse)
- Sortie des fumées supérieure et arrière
- Tirioir à cendres amovible
- Creuset en fonte
- Porte avec double vitrage

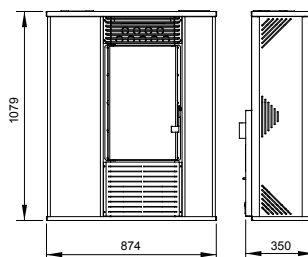

ALICE S1 CERAMICA ★★☆☆



Versioni e colori - Versions and colors - Versions et couleurs



E7030DV

Rosso
Red
Rouge

€ 3.250,00



E7031DV

Bianco
White
Blanc

€ 3.250,00



E7033DV

Cuoio
Leather
Cuir

€ 3.250,00

Stufe pellet aria
Air pellet stoves
Poêles à granulés d'air

A+



Dati tecnici - Technical data - Données techniques

MISURE (H X L X P)
DIMENSIONS (H X L X P)
DIMENSIONS (H X L X P)

107 x 87 x 35 cm

POTENZA TERMOCHIMICA
THERMO-CHEMICAL POWER
PUISSANCE THERMOCHIMIQUE

14,10 kW

POTENZA NOMINALE
RATED OUTPUT
PUISSANCE NOMINALE

12,68 kW

RENDIMENTO A POTENZA MIN/MAX
MIN/MAX EFFICIENCY
RENDIMENT MIN/MAX

95,28 - 89,92 %

CLASSE DI EFFICIENZA ENERGETICA
ENERGY EFFICIENCY CLASS
CLASSE D'EFFICACITÉ ÉNERGÉTIQUE

A+

CONFORME ALLE NORME
IN CONFORMITY TO STANDARD
CONFORME AUX RÈGLES

UNI-EN 14785

VOLUME RISCALDABILE MAX
MAX HEATABLE VOLUME
VOLUME CHAUFFABLE MAX

360 m³

CONSUMO ORARIO MIN/MAX
MIN/MAX CONSUMPTION
CONSUMMATION MIN/MAX

1,27 - 2,91 kg/h

ALIMENTAZIONE ELETTRICA
TENSION - FREQUENCY
TENSION - FRÉQUENCE

230 V - 50 Hz

ASSORBIMENTO ELETTRICO NOMINALE
RATED POWER CONSUMPTION
CONSUMMATION ÉLECTRIQUE NOMINALE

128,8 W

CAPACITÀ SERBATOIO
RESERVOIR CAPACITY
CAPACITÉ DU RESERVOIR

23 Kg

DIAMETRO SCARICO FUMI
SMOKE OUTLET DIAMETER
DIAMÈTRE SORTIE DES FUMÉES

80 mm

PESO (CON IMBALLO)
WEIGHT (INCLUDING PACKAGE)
POIDS (AVEC EMBALLAGE)

142 Kg

Caratteristiche particolari

- Telecomando di serie
- Scarico fumi superiore, posteriore
- Cassetto cenere estraibile
- Braciore in ghisa
- Porta doppio vetro

Characteristics

- Remote control included
- Upper and rear Smoke outlet
- Removable ash pan
- Cast iron brazier
- Double glass door

Caractéristique

- Télécommande (incluse)
- Sortie des fumées supérieure et arrière
- Tiroir à cendres amovible
- Creuset en fonte
- Porte avec double vitrage

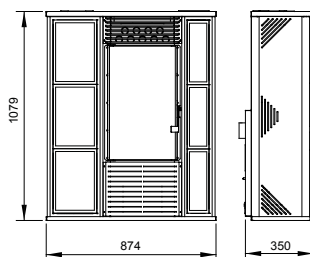

ALICE S1 CANALIZZATA ACCIAIO ★★☆☆



Versioni e colori - Versions and colors - Versions et couleurs



E7100DV

Rosso
Red
Rouge

€ 2.930,00



E7101DV

Beige
Beige
Beige

€ 2.930,00



E7105DV

Bianco
White
Blanc

€ 2.930,00



Stufe pellet aria
Air pellet stoves
Poêles à granulés d'air



Dati tecnici - Technical data - Données techniques

MISURE (H X L X P) DIMENSIONS (H X L X P) DIMENSIONS (H X L X P)	107 x 87 x 35 cm
POTENZA TERMOCHIMICA THERMO-CHEMICAL POWER PUISSANCE THERMOCHIMIQUE	14,10 kW
POTENZA NOMINALE RATED OUTPUT PUISSANCE NOMINALE	12,68 kW
RENDIMENTO A POTENZA MIN/MAX MIN/MAX EFFICIENCY RENDEMENT MIN/MAX	95,28 - 89,92 %
CLASSE DI EFFICIENZA ENERGETICA ENERGY EFFICIENCY CLASS CLASSE D'EFFICACITÉ ÉNERGÉTIQUE	A+
CONFORME ALLE NORME IN CONFORMITY TO STANDARD CONFORME AUX RÈGLES	UNI-EN 14785
VOLUME RISCALDABILE MAX MAX HEATABLE VOLUME VOLUME CHAUFFABLE MAX	360 m ³
CONSUMO ORARIO MIN/MAX MIN/MAX CONSUMPTION CONSOMMATION MIN/MAX	1,27 - 2,91 kg/h
ALIMENTAZIONE ELETTRICA TENSION - FREQUENCY TENSION - FRÉQUENCE	230 V - 50 Hz
ASSORBIMENTO ELETTRICO NOMINALE RATED POWER CONSUMPTION CONSOMMATION ÉLECTRIQUE NOMINALE	128,8 W
CAPACITÀ SERBATOIO RESERVOIR CAPACITY CAPACITÉ DU RESERVOIR	23 Kg
DIAMETRO SCARICO FUMI SMOKE OUTLET DIAMETER DIAMÈTRE SORTIE DES FUMÉES	80 mm
PESO (CON IMBALLO) WEIGHT (INCLUDING PACKAGE) POIDS (AVEC EMBALLAGE)	147 Kg

Caratteristiche particolari

- Telecomando di serie
- Scarico fumi superiore, posteriore
- Cassetto cenere estraibile
- Braciore in ghisa
- Porta doppio vetro
- Kit canalizzazione di serie

Characteristics

- Remote control included
- Upper and rear Smoke outlet
- Removable ash pan
- Cast iron brazier
- Double glass door
- Ducting Kit included

Caractéristique

- Télécommande (incluse)
- Sortie des fumées supérieure et arrière
- Tiroir à cendres amovible
- Creuset en fonte
- Porte avec double vitrage
- Kit de canalisation (incluse)

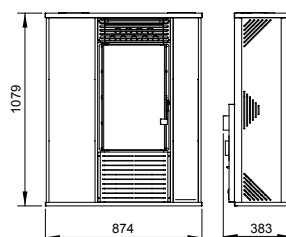

ALICE S1 CANALIZZATA VETRO ★★☆☆



Versioni e colori - Versions and colors - Versions et couleurs



E7110DV

Rosso
Red
Rouge

€ 3.182,00



E7111DV

Bianco
White
Blanc

€ 3.182,00



E7112DV

Nero
Black
Noir

€ 3.182,00

Stufe pellet aria
Air pellet stoves
Poêles à granulés d'air

A+



Dati tecnici - Technical data - Données techniques

MISURE (H X L X P)
DIMENSIONS (H X L X P)
DIMENSIONS (H X L X P)

107 x 87 x 35 cm

POTENZA TERMOCHIMICA
THERMO-CHEMICAL POWER
PUISSANCE THERMOCHIMIQUE

14,10 kW

POTENZA NOMINALE
RATED OUTPUT
PUISSANCE NOMINALE

12,68 kW

RENDIMENTO A POTENZA MIN/MAX
MIN/MAX EFFICIENCY
RENDEMENT MIN/MAX

95,28 - 89,92 %

CLASSE DI EFFICIENZA ENERGETICA
ENERGY EFFICIENCY CLASS
CLASSE D'EFFICACITÉ ÉNERGÉTIQUE

A+

CONFORME ALLE NORME
IN CONFORMITY TO STANDARD
CONFORME AUX RÈGLES

UNI-EN 14785

VOLUME RISCALDABILE MAX
MAX HEATABLE VOLUME
VOLUME CHAUFFABLE MAX

360 m³

CONSUMO ORARIO MIN/MAX
MIN/MAX CONSUMPTION
CONSUMMATION MIN/MAX

1,27 - 2,91 kg/h

ALIMENTAZIONE ELETTRICA
TENSION - FREQUENCY
TENSION - FRÉQUENCE

230 V - 50 Hz

ASSORBIMENTO ELETTRICO NOMINALE
RATED POWER CONSUMPTION
CONSUMMATION ÉLECTRIQUE NOMINALE

128,8 W

CAPACITÀ SERBATOIO
RESERVOIR CAPACITY
CAPACITÉ DU RESERVOIR

23 Kg

DIAMETRO SCARICO FUMI
SMOKE OUTLET DIAMETER
DIAMÈTRE SORTIE DES FUMÉES

80 mm

PESO (CON IMBALLO)
WEIGHT (INCLUDING PACKAGE)
POIDS (AVEC EMBALLAGE)

147 Kg

Caratteristiche particolari

- Telecomando di serie
- Scarico fumi superiore, posteriore
- Cassetto cenere estraibile
- Braciare in ghisa
- Porta doppio vetro
- Kit canalizzazione di serie

Characteristics

- Remote control included
- Upper and rear Smoke outlet
- Removable ash pan
- Cast iron brazier
- Double glass door
- Ducting Kit included

Caractéristique

- Télécommande (incluse)
- Sortie des fumées supérieure et arrière
- Tiroir à cendres amovible
- Creuset en fonte
- Porte avec double vitrage
- Kit de canalisation (incluse)

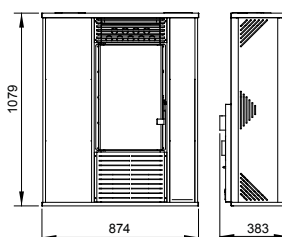

ALICE S1 CANALIZZATA PIETRA ★★☆☆



Versioni e colori - Versions and colors - Versions et couleurs



E7120DV

Ardesia
Slate stone
Ardoise

€ 3.571,00



E7121DV

Pietra Ivory
Ivory stone
Pierre ivoire

€ 3.571,00



Stufe pellet aria
Air pellet stoves
Poêles à granulés d'air

A+



Dati tecnici - Technical data - Données techniques

MISURE (H X L X P) DIMENSIONS (H X L X P) DIMENSIONS (H X L X P)	107 x 87 x 35 cm
POTENZA TERMOCHIMICA THERMO-CHEMICAL POWER PUISSANCE THERMOCHIMIQUE	14,10 kW
POTENZA NOMINALE RATED OUTPUT PUISSANCE NOMINALE	12,68 kW
RENDIMENTO A POTENZA MIN/MAX MIN/MAX EFFICIENCY RENDEMENT MIN/MAX	95,28 - 89,92 %
CLASSE DI EFFICIENZA ENERGETICA ENERGY EFFICIENCY CLASS CLASSE D'EFFICACITÉ ÉNERGÉTIQUE	A+
CONFORME ALLE NORME IN CONFORMITY TO STANDARD CONFORME AUX RÈGLES	UNI-EN 14785
VOLUME RISCALDABILE MAX MAX HEATABLE VOLUME VOLUME CHAUFFABLE MAX	360 m ³
CONSUMO ORARIO MIN/MAX MIN/MAX CONSUMPTION CONSOMMATION MIN/MAX	1,27 - 2,91 kg/h
ALIMENTAZIONE ELETTRICA TENSION - FREQUENCY TENSION - FRÉQUENCE	230 V - 50 Hz
ASSORBIMENTO ELETTRICO NOMINALE RATED POWER CONSUMPTION CONSOMMATION ÉLECTRIQUE NOMINALE	128,8 W
CAPACITÀ SERBATOIO RESERVOIR CAPACITY CAPACITÉ DU RESERVOIR	23 Kg
DIAMETRO SCARICO FUMI SMOKE OUTLET DIAMETER DIAMÈTRE SORTIE DES FUMÉES	80 mm
PESO (CON IMBALLO) WEIGHT (INCLUDING PACKAGE) POIDS (AVEC EMBALLAGE)	147 Kg

Caratteristiche particolari

- Telecomando di serie
- Scarico fumi superiore, posteriore
- Cassetto cenere estraibile
- Braciare in ghisa
- Porta doppio vetro
- Kit canalizzazione di serie

Characteristics

- Remote control included
- Upper and rear Smoke outlet
- Removable ash pan
- Cast iron brazier
- Double glass door
- Ducting Kit included

Caractéristique

- Télécommande (incluse)
- Sortie des fumées supérieure et arrière
- Tiroir à cendres amovible
- Creuset en fonte
- Porte avec double vitrage
- Kit de canalisation (incluse)

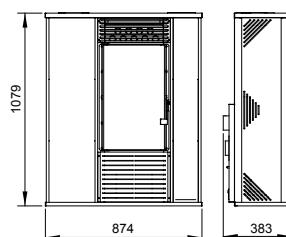

ALICE S1 CANALIZZATA CERAMICA ★★☆☆



Versioni e colori - Versions and colors - Versions et couleurs



E7130DV

Rosso
Red
Rouge

€ 3.571,00



E7131DV

Bianco
White
Blanc

€ 3.571,00



E7133DV

Cuoio
Leather
Cuir

€ 3.571,00

Stufe pellet aria
Air pellet stoves
Poêles à granulés d'air

A+



Dati tecnici - Technical data - Données techniques

MISURE (H X L X P)
DIMENSIONS (H X L X P)
DIMENSIONS (H X L X P)

107 x 87 x 35 cm

POTENZA TERMOCHIMICA
THERMO-CHEMICAL POWER
PUISSANCE THERMOCHIMIQUE

14,10 kW

POTENZA NOMINALE
RATED OUTPUT
PUISSANCE NOMINALE

12,68 kW

RENDIMENTO A POTENZA MIN/MAX
MIN/MAX EFFICIENCY
RENDEMENT MIN/MAX

95,28 - 89,92 %

CLASSE DI EFFICIENZA ENERGETICA
ENERGY EFFICIENCY CLASS
CLASSE D'EFFICACITÉ ÉNERGÉTIQUE

A+

CONFORME ALLE NORME
IN CONFORMITY TO STANDARD
CONFORME AUX RÈGLES

UNI-EN 14785

VOLUME RISCALDABILE MAX
MAX HEATABLE VOLUME
VOLUME CHAUFFABLE MAX

360 m³

CONSUMO ORARIO MIN/MAX
MIN/MAX CONSUMPTION
CONSUMMATION MIN/MAX

1,27 - 2,91 kg/h

ALIMENTAZIONE ELETTRICA
TENSION - FREQUENCY
TENSION - FRÉQUENCE

230 V - 50 Hz

ASSORBIMENTO ELETTRICO NOMINALE
RATED POWER CONSUMPTION
CONSUMMATION ÉLECTRIQUE NOMINALE

128,8 W

CAPACITÀ SERBATOIO
RESERVOIR CAPACITY
CAPACITÉ DU RESERVOIR

23 Kg

DIAMETRO SCARICO FUMI
SMOKE OUTLET DIAMETER
DIAMÈTRE SORTIE DES FUMÉES

80 mm

PESO (CON IMBALLO)
WEIGHT (INCLUDING PACKAGE)
POIDS (AVEC EMBALLAGE)

147 Kg

Caratteristiche particolari

- Telecomando di serie
- Scarico fumi superiore, posteriore
- Cassetto cenere estraibile
- Braciare in ghisa
- Porta doppio vetro
- Kit canalizzazione di serie

Characteristics

- Remote control included
- Upper and rear Smoke outlet
- Removable ash pan
- Cast iron brazier
- Double glass door
- Ducting Kit included

Caractéristique

- Télécommande (include)
- Sortie des fumées supérieure et arrière
- Tiroir à cendres amovible
- Creuset en fonte
- Porte avec double vitrage
- Kit de canalisation (include)

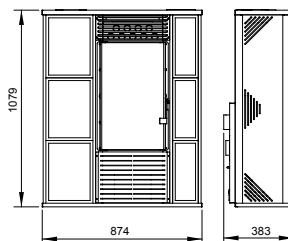

ECLIPSE PLUS ACCIAIO ★★☆☆



Versioni e colori - Versions and colors - Versions et couleurs



P5252

Nero
Black
Noir

€ 4.063,00

Accessori - Accessories - Accessoires



K1093

Modulo Wi-Fi opzionale
Module card Wi Fi available as an option
Module Wi Fi en option

€ 290,00



AC1004

Kit canalizzazione opzionale
Ducting Kit available as an option
Kit de canalisation optionnel

€ 350,00



Stufe pellet aria
Air pellet stoves
Poêles à granulés d'air

A+



Dati tecnici - Technical data - Données techniques

MISURE (H X L X P)
DIMENSIONS (H X L X P)
DIMENSIONS (H X L X P) 115 x 72 x 53 cm

POTENZA TERMOCHIMICA
THERMO-CHEMICAL POWER
PUISSANCE THERMOCHIMIQUE 16,35 kW

POTENZA NOMINALE
RATED OUTPUT
PUISSANCE NOMINALE 14,60 kW

RENDIMENTO A POTENZA MIN/MAX
MIN/MAX EFFICIENCY
RENDEMENT MIN/MAX 93,00 - 86,20 %

CLASSE DI EFFICIENZA ENERGETICA
ENERGY EFFICIENCY CLASS
CLASSE D'EFFICACITÀ ÉNERGÉTIQUE A+

CONFORME ALLE NORME
IN CONFORMITY TO STANDARD
CONFORME AUX RÈGLES UNI-EN 14785

VOLUME RISCALDABILE MAX
MAX HEATABLE VOLUME
VOLUME CHAUFFABLE MAX 418 m³

CONSUMO ORARIO MIN/MAX
MIN/MAX CONSUMPTION
CONSOMMATION MIN/MAX 1,30 - 3,30 kg/h

ALIMENTAZIONE ELETTRICA
TENSION - FREQUENCY
TENSION - FRÉQUENCE 230 V - 50 Hz

ASSORBIMENTO ELETTRICO NOMINALE
RATED POWER CONSUMPTION
CONSOMMATION ÉLECTRIQUE NOMINALE 153 W

CAPACITÀ SERBATOIO
RESERVOIR CAPACITY
CAPACITÉ DU RESERVOIR 19 Kg

DIAMETRO SCARICO FUMI
SMOKE OUTLET DIAMETER
DIAMÈTRE SORTIE DES FUMÉES 80 mm

PESO (CON IMBALLO)
WEIGHT (INCLUDING PACKAGE)
POIDS (AVEC EMBALLAGE) 165 Kg

Caratteristiche particolari

- Telecomando di serie
- Scarico fumi posteriore
- Cassetto cenere estraibile
- Sistema di pulizia automatica del braciere

Characteristics

- Remote control included
- Rear Smoke outlet
- Removable ash pan
- Automatic cleaning system of the brazier

Caractéristique

- Télécommande (incluse)
- Sortie des fumées arrière
- Tiroir à cendres amovible
- Systeme autonettoyant du creuset

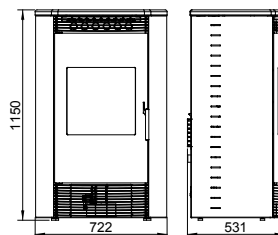

ECLIPSE PLUS VETRO ★★★



Versioni e colori - Versions and colors - Versions et couleurs



P5202

Vetro
Glass
Verre

€ 4.200,00

Accessori - Accessories - Accessoires



K1093

Modulo Wi-Fi opzionale
Module card Wi Fi available as an option
Module Wi Fi en option

€ 290,00



AC1004

Kit canalizzazione opzionale
Ducting Kit available as an option
Kit de canalisation optionnel

€ 350,00

Stufe pellet aria
Air pellet stoves
Poêles à granulés d'air

A+



Dati tecnici - Technical data - Données techniques

MISURE (H X L X P)
DIMENSIONS (H X L X P)
DIMENSIONS (H X L X P)

115 x 72 x 53 cm

POTENZA TERMOCHIMICA
THERMO-CHEMICAL POWER
PUISSANCE THERMOCHIMIQUE

16,35 kW

POTENZA NOMINALE
RATED OUTPUT
PUISSANCE NOMINALE

14,60 kW

RENDIMENTO A POTENZA MIN/MAX
MIN/MAX EFFICIENCY
RENDIMENT MIN/MAX

93,00 - 86,20 %

CLASSE DI EFFICIENZA ENERGETICA
ENERGY EFFICIENCY CLASS
CLASSE D'EFFICACITÉ ÉNERGÉTIQUE

A+

CONFORME ALLE NORME
IN CONFORMITY TO STANDARD
CONFORME AUX RÉGLES

UNI-EN 14785

VOLUME RISCALDABILE MAX
MAX HEATABLE VOLUME
VOLUME CHAUFFABLE MAX

418 m³

CONSUMO ORARIO MIN/MAX
MIN/MAX CONSUMPTION
CONSOMMATION MIN/MAX

1,30 - 3,30 kg/h

ALIMENTAZIONE ELETTRICA
TENSION - FREQUENCY
TENSION - FRÉQUENCE

230 V - 50 Hz

ASSORBIMENTO ELETTRICO NOMINALE
RATED POWER CONSUMPTION
CONSOMMATION ÉLECTRIQUE NOMINALE

153 W

CAPACITÀ SERBATOIO
RESERVOIR CAPACITY
CAPACITÉ DU RESERVOIR

19 Kg

DIAMETRO SCARICO FUMI
SMOKE OUTLET DIAMETER
DIAMÈTRE SORTIE DES FUMÉES

80 mm

PESO (CON IMBALLO)
WEIGHT (INCLUDING PACKAGE)
POIDS (AVEC EMBALLAGE)

165 Kg

Caratteristiche particolari

- Telecomando di serie
- Scarico fumi posteriore
- Cassetto cenere estraibile
- Sistema di pulizia automatica del braciere

Characteristics

- Remote control included
- Rear Smoke outlet
- Removable ash pan
- Automatic cleaning system of the brazier

Caractéristique

- Télécommande (incluse)
- Sortie des fumées arrière
- Tiroir à cendres amovible
- Systeme autonettoyant du creuset

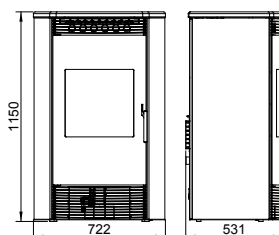

ECLIPSE PLUS SERPENTINO ★ ★ ★ ★



Versioni e colori - Versions and colors - Versions et couleurs



P5200

Serpentino
Serpentine
Serpentine

€ 4.339,00

Accessori - Accessories - Accessoires



K1093

Modulo Wi-Fi opzionale
Module card Wi Fi available as an option
Module Wi Fi en option

€ 290,00



AC1004

Kit canalizzazione opzionale
Ducting Kit available as an option
Kit de canalisation optionnel

€ 350,00



Stufe pellet aria
Air pellet stoves
Poêles à granulés d'air

A+



Dati tecnici - Technical data - Données techniques

MISURE (H X L X P)
DIMENSIONS (H X L X P)
DIMENSIONS (H X L X P)

115 x 72 x 53 cm

POTENZA TERMOCHIMICA
THERMO-CHEMICAL POWER
PUISSANCE THERMOCHIMIQUE

16,35 kW

POTENZA NOMINALE
RATED OUTPUT
PUISSANCE NOMINALE

14,60 kW

RENDIMENTO A POTENZA MIN/MAX
MIN/MAX EFFICIENCY
RENDEMENT MIN/MAX

93,00 - 86,20 %

CLASSE DI EFFICIENZA ENERGETICA
ENERGY EFFICIENCY CLASS
CLASSE D'EFFICACITÀ ÉNERGÉTIQUE

A+

CONFORME ALLE NORME
IN CONFORMITY TO STANDARD
CONFORME AUX RÉGLES

UNI-EN 14785

VOLUME RISCALDABILE MAX
MAX HEATABLE VOLUME
VOLUME CHAUFFABLE MAX

418 m³

CONSUMO ORARIO MIN/MAX
MIN/MAX CONSUMPTION
CONSOMMATION MIN/MAX

1,30 - 3,30 kg/h

ALIMENTAZIONE ELETTRICA
TENSION - FREQUENCY
TENSION - FRÉQUENCE

230 V - 50 Hz

ASSORBIMENTO ELETTRICO NOMINALE
RATED POWER CONSUMPTION
CONSOMMATION ÉLECTRIQUE NOMINALE

153 W

CAPACITÀ SERBATOIO
RESERVOIR CAPACITY
CAPACITÉ DU RESERVOIR

19 Kg

DIAMETRO SCARICO FUMI
SMOKE OUTLET DIAMETER
DIAMÈTRE SORTIE DES FUMÉES

80 mm

PESO (CON IMBALLO)
WEIGHT (INCLUDING PACKAGE)
POIDS (AVEC EMBALLAGE)

165 Kg

Caratteristiche particolari

- Telecomando di serie
- Scarico fumi posteriore
- Cassetto cenere estraibile
- Sistema di pulizia automatica del braciere
- Top in pietra naturale

Characteristics

- Remote control included
- Rear Smoke outlet
- Removable ash pan
- Automatic cleaning system of the brazier
- Natural stone top

Caractéristique

- Télécommande (incluse)
- Sortie des fumées arrière
- Tiroir à cendres amovible
- Systeme autonettoyant du creuset
- Plateau supérieure en pierre naturelle

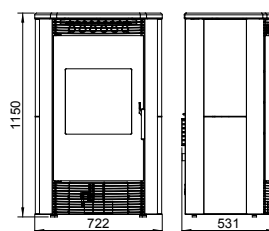

ISCHIA PLUS ★★★★



Versioni e colori - Versions and colors - Versions et couleurs



C3110P

Rosso
Red
Rouge

€ 2.792,00



C3111P

Bianco
White
Blanc

€ 2.792,00

Accessori - Accessories - Accessoires



K1093

Modulo Wi-Fi opzionale
Module card Wi Fi available as an option
Module Wi Fi en option

€ 290,00



AC1003

Kit canalizzazione opzionale
Ducting Kit available as an option
Kit de canalisation optionnel

€ 350,00

Stufe pellet aria
Air pellet stoves
Poêles à granulés d'air

A+



Dati tecnici - Technical data - Données techniques

MISURE (H X L X P)
DIMENSIONS (H X L X P)
DIMENSIONS (H X L X P)

103 x 52 x 51 cm

POTENZA TERMOCHIMICA
THERMO-CHEMICAL POWER
PUISSANCE THERMOCHIMIQUE

13,22 kW

POTENZA NOMINALE
RATED OUTPUT
PUISSANCE NOMINALE

11,52 kW

RENDIMENTO A POTENZA MIN/MAX
MIN/MAX EFFICIENCY
RENDEMENT MIN/MAX

93,07 - 87,15 %

CLASSE DI EFFICIENZA ENERGETICA
ENERGY EFFICIENCY CLASS
CLASSE D'EFFICACITÉ ÉNERGÉTIQUE

A+

CONFORME ALLE NORME
IN CONFORMITY TO STANDARD
CONFORME AUX RÈGLES

UNI-EN 14785

VOLUME RISCALDABILE MAX
MAX HEATABLE VOLUME
VOLUME CHAUFFABLE MAX

330 m³

CONSUMO ORARIO MIN/MAX
MIN/MAX CONSUMPTION
CONSUMMATION MIN/MAX

1,00 - 2,73 kg/h

ALIMENTAZIONE ELETTRICA
TENSION - FREQUENCY
TENSION - FRÉQUENCE

230 V - 50 Hz

ASSORBIMENTO ELETTRICO NOMINALE
RATED POWER CONSUMPTION
CONSUMMATION ÉLECTRIQUE NOMINALE

147 W

CAPACITÀ SERBATOIO
RESERVOIR CAPACITY
CAPACITÉ DU RESERVOIR

20 Kg

DIAMETRO SCARICO FUMI
SMOKE OUTLET DIAMETER
DIAMÈTRE SORTIE DES FUMÉES

80 mm

PESO (CON IMBALLO)
WEIGHT (INCLUDING PACKAGE)
POIDS (AVEC EMBALLAGE)

104 Kg

Caratteristiche particolari

- Telecomando di serie
- Scarico fumi superiore e posteriore
- Cassetto cenere estraibile
- Braciere in ghisa
- Porta doppio vetro
- Uscita aria calda dal lato superiore
- Sistema di pulizia automatica del braciere

Characteristics

- Remote control included
- Upper and rear Smoke outlet
- Removable ash pan
- Cast iron brazier
- Double glass door
- Hot air outlet from the upper side
- Automatic cleaning system of the brazier

Caractéristique

- Télécommande (incluse)
- Sortie des fumées supérieure et arrière
- Tiroir à cendres amovible
- Creuset en fonte
- Porte avec double vitrage
- Sortie d'air chaud par les haut
- Systeme autonettoyant du creuset

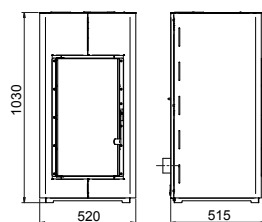

GIOVE PLUS ★ ★ ★

Questa versione fino ad esaurimento scorte
This version while stocks last
Cette version jusqu'à épuisement des stocks



Versioni e colori - Versions and colors - Versions et couleurs



CN2000

Rosso
Red
Rouge

€ 2.354,00



CN2001

Bianco
White
Blanc

€ 2.354,00



CN2002

Nero
Black
Noir

€ 2.354,00



CN2003

Bronzo
Bronze
Bronze

€ 2.354,00

Accessori - Accessories - Accessoires



K1093

Modulo Wi-Fi opzionale
Module card Wi Fi available as an option
Module Wi Fi en option

€ 290,00



Stufe pellet aria
Air pellet stoves
Poêles à granulés d'air

A+



Dati tecnici - Technical data - Données techniques

MISURE (H X L X P)
DIMENSIONS (H X L X P)
DIMENSIONS (H X L X P)

110 x 50 x 51 cm

POTENZA TERMOCHIMICA
THERMO-CHEMICAL POWER
PUISSANCE THERMOCHIMIQUE

10,83 kW

POTENZA NOMINALE
RATED OUTPUT
PUISSANCE NOMINALE

9,54 kW

RENDIMENTO A POTENZA MIN/MAX
MIN/MAX EFFICIENCY
RENDEMENT MIN/MAX

90,20 - 88,04 %

CLASSE DI EFFICIENZA ENERGETICA
ENERGY EFFICIENCY CLASS
CLASSE D'EFFICACITÉ ÉNERGÉTIQUE

A+

CONFORME ALLE NORME
IN CONFORMITY TO STANDARD
CONFORME AUX RÉGLES

UNI-EN 14785

VOLUME RISCALDABILE MAX
MAX HEATABLE VOLUME
VOLUME CHAUFFABLE MAX

263 m³

CONSUMO ORARIO MIN/MAX
MIN/MAX CONSUMPTION
CONSOMMATION MIN/MAX

0,91 - 2,19 kg/h

ALIMENTAZIONE ELETTRICA
TENSION - FREQUENCY
TENSION - FRÉQUENCE

230 V - 50 Hz

ASSORBIMENTO ELETTRICO NOMINALE
RATED POWER CONSUMPTION
CONSOMMATION ÉLECTRIQUE NOMINALE

31 W

CAPACITÀ SERBATOIO
RESERVOIR CAPACITY
CAPACITÉ DU RESERVOIR

16 Kg

DIAMETRO SCARICO FUMI
SMOKE OUTLET DIAMETER
DIAMÈTRE SORTIE DES FUMÉES

80 mm

PESO (CON IMBALLO)
WEIGHT (INCLUDING PACKAGE)
POIDS (AVEC EMBALLAGE)

102 Kg

Caratteristiche particolari

- Stufa a convezione naturale
- Telecomando di serie
- Scarico fumi superiore e posteriore
- Braciere e porta in ghisa
- Cassetto cenere estraibile
- Sistema di pulizia automatica del braciere

Characteristics

- Natural convection stove
- Remote control included
- Upper and rear Smoke outlet
- Cast iron brazier and door
- Removable ash pan
- Automatic cleaning system of the brazier

Caractéristique

- Poêle à convection naturelle
- Télécommande (incluse)
- Sortie des fumées supérieure et arrière
- Creuset et porte en fonte
- Tiroir à cendres amovible
- Systeme autonettoyant du creuset

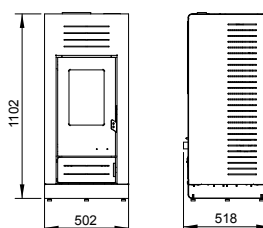

VENERE PLUS ★ ★ ★

Questa versione fino ad esaurimento scorte
This version while stocks last
Cette version jusqu'à épuisement des stocks

Versioni e colori - Versions and colors - Versions et couleurs



CN3000

Rosso
Red
Rouge

€ 2.354,00



CN3001

Bianco
White
Blanc

€ 2.354,00



CN3002

Nero
Black
Noir

€ 2.354,00



CN3003

Bronzo
Bronze
Bronze

€ 2.354,00

Accessori - Accessories - Accessoires



K1093

Modulo Wi-Fi opzionale
Module card Wi Fi available as an option
Module Wi Fi en option

€ 290,00

Stufe pellet aria
Air pellet stoves
Poêles à granulés d'air

A+



Dati tecnici - Technical data - Données techniques

MISURE (H X L X P)
DIMENSIONS (H X L X P)
DIMENSIONS (H X L X P)

110 x 54 x 51 cm

POTENZA TERMOCHIMICA
THERMO-CHEMICAL POWER
PUISSANCE THERMOCHIMIQUE

10,83 kW

POTENZA NOMINALE
RATED OUTPUT
PUISSANCE NOMINALE

9,54 kW

RENDIMENTO A POTENZA MIN/MAX
MIN/MAX EFFICIENCY
RENDMENT MIN/MAX

90,20 - 88,04 %

CLASSE DI EFFICIENZA ENERGETICA
ENERGY EFFICIENCY CLASS
CLASSE D'EFFICACITÉ ÉNERGÉTIQUE

A+

CONFORME ALLE NORME
IN CONFORMITY TO STANDARD
CONFORME AUX RÈGLES

UNI-EN 14785

VOLUME RISCALDABILE MAX
MAX HEATABLE VOLUME
VOLUME CHAUFFABLE MAX

263 m³

CONSUMO ORARIO MIN/MAX
MIN/MAX CONSUMPTION
CONSUMMATION MIN/MAX

0,91 - 2,19 kg/h

ALIMENTAZIONE ELETTRICA
TENSION - FREQUENCY
TENSION - FRÉQUENCE

230 V - 50 Hz

ASSORBIMENTO ELETTRICO NOMINALE
RATED POWER CONSUMPTION
CONSUMMATION ÉLECTRIQUE NOMINALE

31 W

CAPACITÀ SERBATOIO
RESERVOIR CAPACITY
CAPACITÉ DU RESERVOIR

16 Kg

DIAMETRO SCARICO FUMI
SMOKE OUTLET DIAMETER
DIAMÈTRE SORTIE DES FUMÉES

80 mm

PESO (CON IMBALLO)
WEIGHT (INCLUDING PACKAGE)
POIDS (AVEC EMBALLAGE)

102 Kg

Caratteristiche particolari

- Stufa a convezione naturale
- Telecomando di serie
- Scarico fumi superiore e posteriore
- Braciiera e porta in ghisa
- Cassetto cenere estraibile
- Sistema di pulizia automatica del braciiera

Characteristics

- Natural convection stove
- Remote control included
- Upper and rear Smoke outlet
- Cast iron brazier and door
- Removable ash pan
- Automatic cleaning system of the brazier

Caractéristique

- Poêle à convection naturelle
- Télécommande (incluse)
- Sortie des fumées supérieure et arrière
- Creuset et porte en fonte
- Tiroir à cendres amovible
- Système autonettoyant du creuset

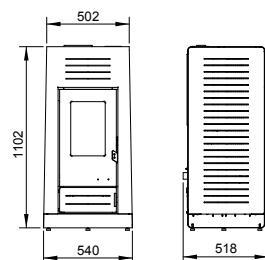

ELBA PLUS ACCIAIO ★★☆☆



Versioni e colori - Versions and colors - Versions et couleurs



P6000

Rosso
Red
Rouge

€ 4.190,00



P6001

Effetto legno
Wooden finish
Imitation bois

€ 4.190,00

Accessori - Accessories - Accessoires



K1093

Modulo Wi-Fi opzionale
Module card Wi Fi available as an option
Module Wi Fi en option

€ 290,00



Stufe pellet aria
Air pellet stoves
Poêles à granulés d'air

A+



Dati tecnici - Technical data - Données techniques

MISURE (H X L X P) DIMENSIONS (H X L X P) DIMENSIONS (H X L X P)	122 x 59 x 48 cm
POTENZA TERMOCHIMICA THERMO-CHEMICAL POWER PUISSANCE THERMOCHIMIQUE	15,57 kW
POTENZA NOMINALE RATED OUTPUT PUISSANCE NOMINALE	14,49 kW
RENDIMENTO A POTENZA MIN/MAX MIN/MAX EFFICIENCY RENDEMENT MIN/MAX	96,16 - 93,07 %
CLASSE DI EFFICIENZA ENERGETICA ENERGY EFFICIENCY CLASS CLASSE D'EFFICACITÉ ÉNERGÉTIQUE	A+
CONFORME ALLE NORME IN CONFORMITY TO STANDARD CONFORME AUX RÈGLES	UNI-EN 14785
VOLUME RISCALDABILE MAX MAX HEATABLE VOLUME VOLUME CHAUFFABLE MAX	415 m ³
CONSUMO ORARIO MIN/MAX MIN/MAX CONSUMPTION CONSOMMATION MIN/MAX	1,36 - 3,21 kg/h
ALIMENTAZIONE ELETTRICA TENSION - FREQUENCY TENSION - FRÉQUENCE	230 V - 50 Hz
ASSORBIMENTO ELETTRICO NOMINALE RATED POWER CONSUMPTION CONSOMMATION ÉLECTRIQUE NOMINALE	130 W
CAPACITÀ SERBATOIO RESERVOIR CAPACITY CAPACITÉ DU RESERVOIR	28 Kg
DIAMETRO SCARICO FUMI SMOKE OUTLET DIAMETER DIAMÈTRE SORTIE DES FUMÉES	80 mm
PESO (CON IMBALLO) WEIGHT (INCLUDING PACKAGE) POIDS (AVEC EMBALLAGE)	162 Kg

Caratteristiche particolari

- Telecomando di serie
- Scarico fumi posteriore
- Cassetto cenere estraibile
- Braciere in ghisa
- Porta doppio vetro
- Sistema di pulizia automatica del braciere
- Kit canalizzazione di serie

Characteristics

- Remote control included
- Rear Smoke outlet
- Removable ash pan
- Cast iron brazier
- Double glass door
- Automatic cleaning system of the brazier
- Ducting Kit included

Caractéristique

- Télécommande (include)
- Sortie des fumées arrière
- Tiroir à cendres amovible
- Creuset en fonte
- Porte avec double vitrage
- Systeme autonettoyant du creuset
- Kit de canalisation (include)

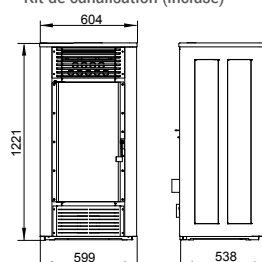

ELBA PLUS CERAMICA ★★★



Versioni e colori - Versions and colors - Versions et couleurs



P6050

Rosso
Red
Rouge

€ 4.659,00



P6051

Effetto legno
Wooden finish
Imitation bois

€ 4.659,00

Accessori - Accessories - Accessoires



K1093

Modulo Wi-Fi opzionale
Module card Wi Fi available as an option
Module Wi Fi en option

€ 290,00

Stufe pellet aria
Air pellet stoves
Poêles à granulés d'air

A+



Dati tecnici - Technical data - Données techniques

MISURE (H X L X P)
DIMENSIONS (H X L X P)
DIMENSIONS (H X L X P)

122 x 59 x 48 cm

POTENZA TERMOCHIMICA
THERMO-CHEMICAL POWER
PUISSANCE THERMOCHIMIQUE

15,57 kW

POTENZA NOMINALE
RATED OUTPUT
PUISSANCE NOMINALE

14,49 kW

RENDIMENTO A POTENZA MIN/MAX
MIN/MAX EFFICIENCY
RENDMENT MIN/MAX

96,16 - 93,07 %

CLASSE DI EFFICIENZA ENERGETICA
ENERGY EFFICIENCY CLASS
CLASSE D'EFFICACITÉ ÉNERGÉTIQUE

A+

CONFORME ALLE NORME
IN CONFORMITY TO STANDARD
CONFORME AUX RÈGLES

UNI-EN 14785

VOLUME RISCALDABILE MAX
MAX HEATABLE VOLUME
VOLUME CHAUFFABLE MAX

415 m³

CONSUMO ORARIO MIN/MAX
MIN/MAX CONSUMPTION
CONSUMMATION MIN/MAX

1,36 - 3,21 kg/h

ALIMENTAZIONE ELETTRICA
TENSION - FREQUENCY
TENSION - FRÉQUENCE

230 V - 50 Hz

ASSORBIMENTO ELETTRICO NOMINALE
RATED POWER CONSUMPTION
CONSUMMATION ÉLECTRIQUE NOMINALE

130 W

CAPACITÀ SERBATOIO
RESERVOIR CAPACITY
CAPACITÉ DU RESERVOIR

28 Kg

DIAMETRO SCARICO FUMI
SMOKE OUTLET DIAMETER
DIAMÈTRE SORTIE DES FUMÉES

80 mm

PESO (CON IMBALLO)
WEIGHT (INCLUDING PACKAGE)
POIDS (AVEC EMBALLAGE)

189 Kg

Caratteristiche particolari

- Telecomando di serie
- Scarico fumi posteriore
- Cassetto cenere estraibile
- Braciere in ghisa
- Porta doppio vetro
- Sistema di pulizia automatica del braciere
- Kit canalizzazione di serie

Characteristics

- Remote control included
- Rear Smoke outlet
- Removable ash pan
- Cast iron brazier
- Double glass door
- Automatic cleaning system of the brazier
- Ducting Kit included

Caractéristique

- Télécommande (include)
- Sortie des fumées arrière
- Tiroir à cendres amovible
- Creuset en fonte
- Porte avec double vitrage
- Systeme autonettoyant du creuset
- Kit de canalisation (include)

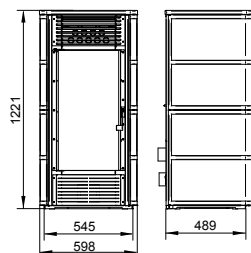

- 
- INSERTI PELLET ARIA
 - AIR PELLET INSERTS
 - INSERTS DE GRANULÉS D'AIR



Versioni e colori - Versions and colors - Versions et couleurs



II5600

Nero
Black
Noir

€ 3.205,00

Accessori - Accessories - Accessoires



KI5200

Kit struttura portainserto
Support
Support

€ 190,00

A+



Dati tecnici - Technical data - Données techniques

MISURE (H X L X P)
DIMENSIONS (H X L X P)
DIMENSIONS (H X L X P)

58 x 85 x 61 cm

POTENZA TERMOCHIMICA
THERMO-CHEMICAL POWER
PUISSANCE THERMOCHIMIQUE

10,50 kW

POTENZA NOMINALE
RATED OUTPUT
PUISSANCE NOMINALE

9,30 kW

RENDIMENTO A POTENZA MIN/MAX
MIN/MAX EFFICIENCY
RENDMENT MIN/MAX

93,20 - 88,50 %

CLASSE DI EFFICIENZA ENERGETICA
ENERGY EFFICIENCY CLASS
CLASSE D'EFFICACITÀ ÉNERGÉTIQUE

A+

CONFORME ALLE NORME
IN CONFORMITY TO STANDARD
CONFORME AUX RÈGLES

UNI-EN 14785

VOLUME RISCALDABILE MAX
MAX HEATABLE VOLUME
VOLUME CHAUFFABLE MAX

266 m³

CONSUMO ORARIO MIN/MAX
MIN/MAX CONSUMPTION
CONSOMMATION MIN/MAX

0,82 - 2,14 kg/h

ALIMENTAZIONE ELETTRICA
TENSION - FREQUENCY
TENSION - FRÉQUENCE

230 V - 50 Hz

ASSORBIMENTO ELETTRICO NOMINALE
RATED POWER CONSUMPTION
CONSOMMATION ÉLECTRIQUE NOMINALE

153 W

CAPACITÀ SERBATOIO
RESERVOIR CAPACITY
CAPACITÉ DU RESERVOIR

19 Kg

DIAMETRO SCARICO FUMI
SMOKE OUTLET DIAMETER
DIAMÈTRE SORTIE DES FUMÉES

80 mm

PESO (CON IMBALLO)
WEIGHT (INCLUDING PACKAGE)
POIDS (AVEC EMBALLAGE)

122 Kg

Caratteristiche particolari

- Braciare in ghisa
- Porta doppio vetro
- Bocchetta rifornimento orientabile

Characteristics

- Cast iron brazier
- Double glass door
- Positionable resupply door

Caractéristique

- Creuset en fonte
- Porte avec double vitrage
- Rosace installable dans diverses positions

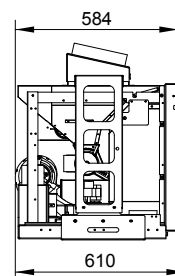
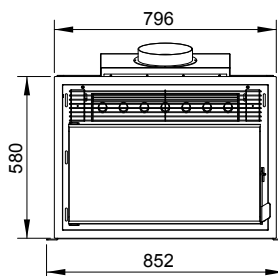

BREMA CANALIZZATO ★★☆☆



Versioni e colori - Versions and colors - Versions et couleurs



II5610

Nero
Black
Noir

€ 3.778,00

Accessori - Accessories - Accessoires



KI5200

Kit struttura portainserito
Support
Support

€ 190,00



Inseriti pellet aria
Air pellet inserts
Inserits de granulés d'air

A+



Dati tecnici - Technical data - Données techniques

MISURE (H X L X P) DIMENSIONS (H X L X P) DIMENSIONS (H X L X P)	58 x 85 x 61 cm
POTENZA TERMOCHIMICA THERMO-CHEMICAL POWER PUISSANCE THERMOCHIMIQUE	10,50 kW
POTENZA NOMINALE RATED OUTPUT PUISSANCE NOMINALE	9,30 kW
RENDIMENTO A POTENZA MIN/MAX MIN/MAX EFFICIENCY RENDEMENT MIN/MAX	93,20 - 88,50 %
CLASSE DI EFFICIENZA ENERGETICA ENERGY EFFICIENCY CLASS CLASSE D'EFFICACITÀ ÉNERGÉTIQUE	A+
CONFORME ALLE NORME IN CONFORMITY TO STANDARD CONFORME AUX RÉGLES	UNI-EN 14785
VOLUME RISCALDABILE MAX MAX HEATABLE VOLUME VOLUME CHAUFFABLE MAX	266 m ³
CONSUMO ORARIO MIN/MAX MIN/MAX CONSUMPTION CONSOMMATION MIN/MAX	0,82 - 2,14 kg/h
ALIMENTAZIONE ELETTRICA TENSION - FREQUENCY TENSION - FRÉQUENCE	230 V - 50 Hz
ASSORBIMENTO ELETTRICO NOMINALE RATED POWER CONSUMPTION CONSOMMATION ÉLECTRIQUE NOMINALE	153 W
CAPACITÀ SERBATOIO RESERVOIR CAPACITY CAPACITÉ DU RESERVOIR	19 Kg
DIAMETRO SCARICO FUMI SMOKE OUTLET DIAMETER DIAMÈTRE SORTIE DES FUMÉES	80 mm
PESO (CON IMBALLO) WEIGHT (INCLUDING PACKAGE) POIDS (AVEC EMBALLAGE)	122 Kg

Caratteristiche particolari

- Braciare in ghisa
- Porta doppio vetro
- Bocchetta rifornimento orientabile
- Kit canalizzazione di serie

Characteristics

- Cast iron brazier
- Double glass door
- Positionable resupply door
- Ducting Kit included

Caractéristique

- Creuset en fonte
- Porte avec double vitrage
- Rosace installable dans diverses positions
- Kit de canalisation (incluse)

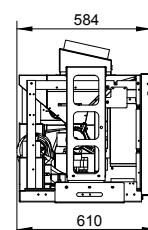
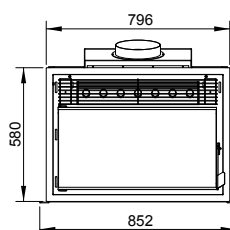

BREMA CAMINO



Versioni e colori - Versions and colors - Versions et couleurs



II5620

Antracite
Anthracite
Anthracite

€ 5.152,00

Inseri pellet aria
Air pellet inserts
Inseris de granulés d'air

A+



Dati tecnici - Technical data - Données techniques

MISURE (H X L X P)
DIMENSIONS (H X L X P)
DIMENSIONS (H X L X P) 250 x 88 x 67 cm

POTENZA TERMOCHIMICA
THERMO-CHEMICAL POWER
PUISSANCE THERMOCHIMIQUE 10,50 kW

POTENZA NOMINALE
RATED OUTPUT
PUISSANCE NOMINALE 9,30 kW

RENDIMENTO A POTENZA MIN/MAX
MIN/MAX EFFICIENCY
RENDIMENT MIN/MAX 93,20 - 88,50 %

CLASSE DI EFFICIENZA ENERGETICA
ENERGY EFFICIENCY CLASS
CLASSE D'EFFICACITÀ ÉNERGÉTIQUE A+

CONFORME ALLE NORME
IN CONFORMITY TO STANDARD
CONFORME AUX RÈGLES UNI-EN 14785

VOLUME RISCALDABILE MAX
MAX HEATABLE VOLUME
VOLUME CHAUFFABLE MAX 266 m³

CONSUMO ORARIO MIN/MAX
MIN/MAX CONSUMPTION
CONSOMMATION MIN/MAX 0,82 - 2,14 kg/h

ALIMENTAZIONE ELETTRICA
TENSION - FREQUENCY
TENSION - FRÉQUENCE 230 V - 50 Hz

ASSORBIMENTO ELETTRICO NOMINALE
RATED POWER CONSUMPTION
CONSOMMATION ÉLECTRIQUE NOMINALE 153 W

CAPACITÀ SERBATOIO
RESERVOIR CAPACITY
CAPACITÉ DU RESERVOIR 19 Kg

DIAMETRO SCARICO FUMI
SMOKE OUTLET DIAMETER
DIAMÈTRE SORTIE DES FUMÉES 80 mm

PESO (CON IMBALLO)
WEIGHT (INCLUDING PACKAGE)
POIDS (AVEC EMBALLAGE) 175 Kg

Caratteristiche particolari

- Braciare in ghisa
- Porta doppio vetro
- Kit canalizzazione di serie
- Telecomando di serie

Characteristics

- Cast iron brazier
- Double glass door
- Ducting Kit included
- Remote control include

Caractéristique

- Creuset en fonte
- Porte avec double vitrage
- Kit de canalisation (include)
- Télécommande (include)

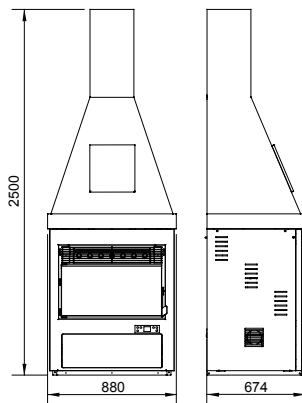

BREMA CAMINO 1

Versioni e colori - Versions and colors - Versions et couleurs



II5650
Rosso
Red
Rouge

€ 4.636,00



II5651
Bianco
White
Blanc

€ 4.636,00



II5653
Bronzo
Bronze
Bronze

€ 4.636,00



Inseri pellet aria
Air pellet inserts
Inserts de granulés d'air

A+



Dati tecnici - Technical data - Données techniques

MISURE (H X L X P) DIMENSIONS (H X L X P) DIMENSIONS (H X L X P)	100 x 85 x 67 cm
POTENZA TERMOCHIMICA THERMO-CHEMICAL POWER PUISSANCE THERMOCHIMIQUE	10,50 kW
POTENZA NOMINALE RATED OUTPUT PUISSANCE NOMINALE	9,30 kW
RENDIMENTO A POTENZA MIN/MAX MIN/MAX EFFICIENCY RENDEMENT MIN/MAX	93,20 - 88,50 %
CLASSE DI EFFICIENZA ENERGETICA ENERGY EFFICIENCY CLASS CLASSE D'EFFICACITÉ ÉNERGÉTIQUE	A+
CONFORME ALLE NORME IN CONFORMITY TO STANDARD CONFORME AUX RÈGLES	UNI-EN 14785
VOLUME RISCALDABILE MAX MAX HEATABLE VOLUME VOLUME CHAUFFABLE MAX	266 m ³
CONSUMO ORARIO MIN/MAX MIN/MAX CONSUMPTION CONSOMMATION MIN/MAX	0,82 - 2,14 kg/h
ALIMENTAZIONE ELETTRICA TENSION - FREQUENCY TENSION - FRÉQUENCE	230 V - 50 Hz
ASSORBIMENTO ELETTRICO NOMINALE RATED POWER CONSUMPTION CONSOMMATION ÉLECTRIQUE NOMINALE	153 W
CAPACITÀ SERBATOIO RESERVOIR CAPACITY CAPACITÉ DU RESERVOIR	19 Kg
DIAMETRO SCARICO FUMI SMOKE OUTLET DIAMETER DIAMÈTRE SORTIE DES FUMÉES	80 mm
PESO (CON IMBALLO) WEIGHT (INCLUDING PACKAGE) POIDS (AVEC EMBALLAGE)	150 Kg

Caratteristiche particolari

- Telecomando di serie
- Braciare in ghisa
- Porta doppio vetro
- Scarico fumi superiore
- Kit canalizzazione di serie

Characteristics

- Remote control included
- Cast iron brazier
- Double glass door
- Upper smoke outlet
- Ducting Kit included

Caractéristique

- Télécommande (incluse)
- Creuset en fonte
- Porte avec double vitrage
- Sortie des fumées supérieure
- Kit de canalisation (incluse)

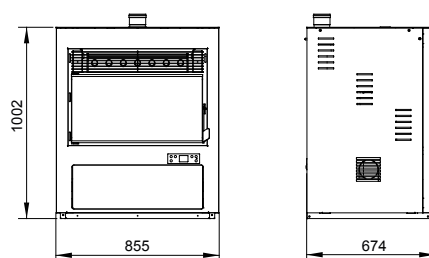

AIR FORCE ONE 20 PLUS ★★★★

Versioni e colori - Versions and colors - Versions et couleurs



II7001SR

Senza rivestimento
Without cover
Sans habillage

€ 5.552,00



II7001

Nero
Black
Noir

€ 5.895,00

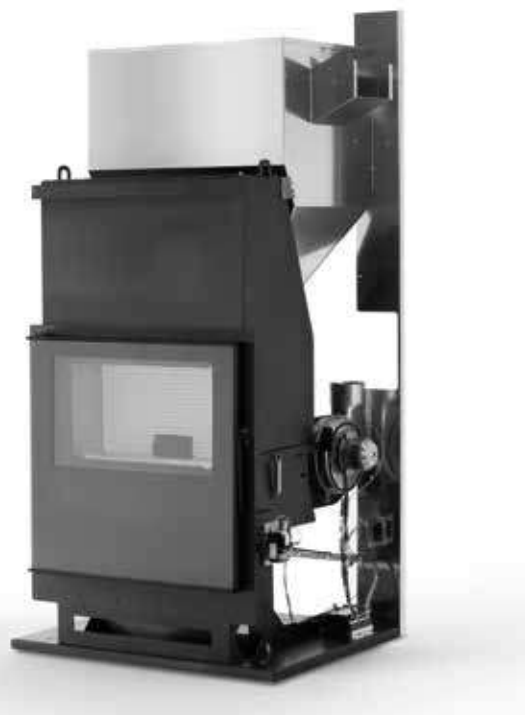

Accessori - Accessories - Accessoires



K1093

Modulo Wi-Fi opzionale
Module card Wi Fi available as an option
Module Wi Fi en option

€ 290,00

Inserti pellet aria
Air pellet inserts
Inserts de granulés d'air

A+



Dati tecnici - Technical data - Données techniques

MISURE (H X L X P) DIMENSIONS (H X L X P) DIMENSIONS (H X L X P)	173 x 96 x 75 cm
POTENZA TERMOCHIMICA THERMO-CHEMICAL POWER PUISSANCE THERMOCHIMIQUE	20,86 kW
POTENZA NOMINALE RATED OUTPUT PUISSANCE NOMINALE	18,84 kW
RENDIMENTO A POTENZA MIN/MAX MIN/MAX EFFICIENCY RENDEMENT MIN/MAX	93,19 - 90,31 %
CLASSE DI EFFICIENZA ENERGETICA ENERGY EFFICIENCY CLASS CLASSE D'EFFICACITÀ ÉNERGÉTIQUE	A+
CONFORME ALLE NORME IN CONFORMITY TO STANDARD CONFORME AUX RÈGLES	UNI-EN 14785
VOLUME RISCALDABILE MAX MAX HEATABLE VOLUME VOLUME CHAUFFABLE MAX	540 m ³
CONSUMO ORARIO MIN/MAX MIN/MAX CONSUMPTION CONSOMMATION MIN/MAX	2,01 - 4,27 kg/h
ALIMENTAZIONE ELETTRICA TENSION - FREQUENCY TENSION - FRÉQUENCE	230 V - 50 Hz
ASSORBIMENTO ELETTRICO NOMINALE RATED POWER CONSUMPTION CONSOMMATION ÉLECTRIQUE NOMINALE	250 W
CAPACITÀ SERBATOIO RESERVOIR CAPACITY CAPACITÉ DU RESERVOIR	80 Kg
DIAMETRO SCARICO FUMI SMOKE OUTLET DIAMETER DIAMÈTRE SORTIE DES FUMÉES	100 mm
PESO (CON IMBALLO) WEIGHT (INCLUDING PACKAGE) POIDS (AVEC EMBALLAGE)	senza rivestimento 280 Kg normale 310 Kg

Caratteristiche particolari

- Telecomando di serie
- Scarico fumi superiore e posteriore
- Serbatoio ad alta capacità
- Cassetto cenere estraibile
- Sistema di pulizia automatica del braciere

Characteristics

- Remote control included
- Upper and rear smoke outlet
- High capacity tank
- Removable ash pan
- Automatic cleaning system of the brazier

Caractéristique

- Télécommande (incluse)
- Sortie des fumées supérieure et arrière
- Réservoir de grande capacité
- Tiroir à cendres amovible
- Système autonettoyant du creuset

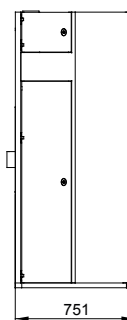
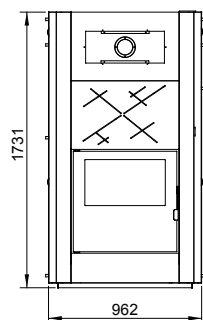

AIR FORCE ONE 28 PLUS ★★☆☆



Versioni e colori - Versions and colors - Versions et couleurs



II6001SR

Senza rivestimento
Without cover
Sans habillage

€ 6.010,00



II6001

Nero
Black
Noir

€ 6.468,00

Accessori - Accessories - Accessoires



K1093

Modulo Wi-Fi opzionale
Module card Wi Fi available as an option
Module Wi Fi en option

€ 290,00



Inseri pellet aria
Air pellet inserts
Inserts de granulés d'air

A+



Dati tecnici - Technical data - Données techniques

MISURE (H X L X P) DIMENSIONS (H X L X P) DIMENSIONS (H X L X P)	173 x 96 x 75 cm
POTENZA TERMOCHIMICA THERMO-CHEMICAL POWER PUISSANCE THERMOCHIMIQUE	29,23 kW
POTENZA NOMINALE RATED OUTPUT PUISSANCE NOMINALE	25,77 kW
RENDIMENTO A POTENZA MIN/MAX MIN/MAX EFFICIENCY RENDEMENT MIN/MAX	93,19 - 88,16 %
CLASSE DI EFFICIENZA ENERGETICA ENERGY EFFICIENCY CLASS CLASSE D'EFFICACITÉ ÉNERGÉTIQUE	A+
CONFORME ALLE NORME IN CONFORMITY TO STANDARD CONFORME AUX RÈGLES	UNI-EN 14785
VOLUME RISCALDABILE MAX MAX HEATABLE VOLUME VOLUME CHAUFFABLE MAX	738 m ³
CONSUMO ORARIO MIN/MAX MIN/MAX CONSUMPTION CONSUMMATION MIN/MAX	2,01 - 5,98 kg/h
ALIMENTAZIONE ELETTRICA TENSION - FREQUENCY TENSION - FRÉQUENCE	230 V - 50 Hz
ASSORBIMENTO ELETTRICO NOMINALE RATED POWER CONSUMPTION CONSUMMATION ÉLECTRIQUE NOMINALE	256 W
CAPACITÀ SERBATOIO RESERVOIR CAPACITY CAPACITÉ DU RESERVOIR	80 Kg
DIAMETRO SCARICO FUMI SMOKE OUTLET DIAMETER DIAMÈTRE SORTIE DES FUMÉES	100 mm
PESO (CON IMBALLO) WEIGHT (INCLUDING PACKAGE) POIDS (AVEC EMBALLAGE)	senza rivestimento 300 Kg normale 330 Kg

Caratteristiche particolari

- Telecomando di serie
- Scarico fumi superiore e posteriore
- Serbatoio ad alta capacità
- Cassetto cenere estraibile
- Sistema di pulizia automatica del braciere

Characteristics

- Remote control included
- Upper and rear smoke outlet
- High capacity tank
- Removable ash pan
- Automatic cleaning system of the brazier

Caractéristique

- Télécommande (incluse)
- Sortie des fumées supérieure et arrière
- Réservoir de grande capacité
- Tiroir à cendres amovible
- Système autonettoyant du creuset

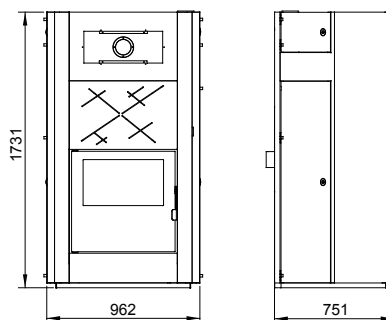



- TERMOSTUFE HYDRO VENTILATE
- HYDRO-VENTILATED THERMO STOVES
- THERMOPOÊLES HYDRO-VENTILÉS



Versioni e colori - Versions and colors - Versions et couleurs



KP3000

Rosso
Red
Rouge

€ 3.686,00



KP3001

Bianco
White
Blanc

€ 3.686,00

Accessori - Accessories - Accessoires



K1093

Modulo Wi-Fi opzionale
Module card Wi Fi available as an option
Module Wi Fi en option

€ 290,00



Termostufe hydro ventilate
Hydro-ventilated thermo stoves
Thermopoêles hydro-ventilés

A+



Dati tecnici - Technical data - Données techniques

MISURE (H X L X P) DIMENSIONS (H X L X P) DIMENSIONS (H X L X P)	116 x 59 x 56 cm
POTENZA TERMOCHIMICA THERMO-CHEMICAL POWER PUISSANCE THERMOCHIMIQUE	15,46 kW
POTENZA RESA PER CONVEZIONE ED IRRAGGIAMENTO CONVECTION AND RADIATION POWER OUTPUT PUISSANCE PAR CONVECTION ET IRRADIATION	2,01 kW
POTENZA RESO ALL'ACQUA WATER POWER OUTPUT PUISSANCE A L'EAU	12,44 kW
RENDIMENTO A POTENZA MIN/MAX MIN/MAX EFFICIENCY RENDMENT MIN/MAX	95,74 - 93,45 %
CLASSE DI EFFICIENZA ENERGETICA ENERGY EFFICIENCY CLASS CLASSE D'EFFICACITÀ ENERGETIQUE	A+
CONFORME ALLE NORME IN CONFORMITY TO STANDARD CONFORME AUX RÈGLES	UNI-EN 14785
VOLUME RISCALDABILE MAX MAX HEATABLE VOLUME VOLUME CHAUFFABLE MAX	414 m ³
CONSUMO ORARIO MIN/MAX MIN/MAX CONSUMPTION CONSOMMATION MIN/MAX	1,18 - 3,14 kg/h
ALIMENTAZIONE ELETTRICA TENSION - FREQUENCY TENSION - FRÉQUENCE	230 V - 50 Hz
ASSORBIMENTO ELETTRICO NOMINALE RATED POWER CONSUMPTION CONSOMMATION ÉLECTRIQUE NOMINALE	90 W
CAPENZA SERBATOIO RESERVOIR CAPACITY CAPACITÉ DU RESERVOIR	30 Kg
TIRAGGIO MINIMO MINIMUM DRAUGHT TIRAGE MINIMUM	10-12 Pa
PRESSIONE DI ESERCIZIO WORKING PRESSURE PRESSION	1,5 bar
DIAMETRO SCARICO FUMI SMOKE OUTLET DIAMETER DIAMÈTRE SORTIE DES FUMÉES	80 mm
PESO (CON IMBALLO) WEIGHT (INCLUDING PACKAGE) POIDS (AVEC EMBALLAGE)	170 Kg

Caratteristiche particolari

- Braciere in ghisa
- Scarico fumi posteriore
- Circolatore elettronico di serie
- Vaso di espansione e valvola di sicurezza di serie
- Possibilità di collegamento di un termostato remoto
- Ventilatori ambiente
- Sistema di pulizia automatica del braciere

Characteristics

- Cast iron brazier
- Rear smoke outlet
- Electronic circulator included
- Expansion vessel and safety valve included
- Possibility to connect a remote thermostat
- Room fans
- Automatic cleaning system of the brazier

Caractéristique

- Creuset en fonte
- Sortie des fumées arrière
- Circulateur électronique incluse
- Vase d'expansion et valve de sécurité incluse
- Possibilité de thermostat déporté
- Ventilateur d'air ambiant
- Système autonettoyant du creuset

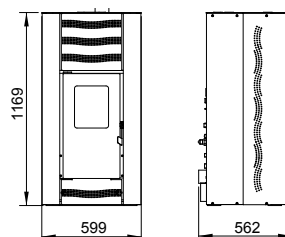

SIVIGLIA S1 ACCIAIO ★★☆☆

Versioni e colori - Versions and colors - Versions et couleurs



KS7200C

Rosso
Red
Rouge

€ 4.613,00



KS7201C

Beige
Beige
Beige

€ 4.613,00

Accessori - Accessories - Accessoires



K1093

Modulo Wi-Fi opzionale
Module card Wi Fi available as an option
Module Wi Fi en option

€ 290,00



K1058

Kit sanitario opzionale
Sanitary water kit (available as an option)
Kit eau sanitaire (en option)

€ 400,00

A++



Dati tecnici - Technical data - Données techniques

MISURE (H X L X P) DIMENSIONS (H X L X P) DIMENSIONS (H X L X P)	118 x 98 x 40 cm
POTENZA TERMOCHIMICA THERMO-CHEMICAL POWER PUISSANCE THERMOCHIMIQUE	20,92 kW
POTENZA RESA PER CONVENZIONE ED IRRAGGIAMENTO CONVECTION AND RADIATION POWER OUTPUT PUISSANCE PAR CONVECTION ET IRRADIATION	3,01 kW
POTENZA RESO ALL'ACQUA WATER POWER OUTPUT PUISSANCE A L'EAU	16,98 kW
RENDIMENTO A POTENZA MIN/MAX MIN/MAX EFFICIENCY RENDEMENT MIN/MAX	97,39 - 95,57 %
CLASSE DI EFFICIENZA ENERGETICA ENERGY EFFICIENCY CLASS CLASSE D'EFFICACITÀ ENERGETIQUE	A++
CONFORME ALLE NORME IN CONFORMITY TO STANDARD CONFORME AUX RÈGLES	UNI-EN 14785
VOLUME RISCALDABILE MAX MAX HEATABLE VOLUME VOLUME CHAUFFABLE MAX	570 m ³
CONSUMO ORARIO MIN/MAX MIN/MAX CONSUMPTION CONSOMMATION MIN/MAX	1,36 - 4,31 kg/h
ALIMENTAZIONE ELETTRICA TENSION - FREQUENCY TENSION - FRÉQUENCE	230 V - 50 Hz
ASSORBIMENTO ELETTRICO NOMINALE RATED POWER CONSUMPTION CONSOMMATION ÉLECTRIQUE NOMINALE	130 W
CAPACITÀ SERBATOIO RESERVOIR CAPACITY CAPACITÉ DU RESERVOIR	27 Kg
TIRAGGIO MINIMO MINIMUM DRAUGHT TIRAGE MINIMUM	10-12 Pa
PRESSIONE DI ESERCIZIO WORKING PRESSURE PRESSION	1,5 bar
DIAMETRO SCARICO FUMI SMOKE OUTLET DIAMETER DIAMÈTRE SORTIE DES FUMÉES	80 mm
PESO (CON IMBALLO) WEIGHT (INCLUDING PACKAGE) POIDS (AVEC EMBALLAGE)	acciaio 202 Kg

Caratteristiche particolari

- Scarico fumi superiore, posteriore e laterale
- Circulatore elettronico di serie
- Vaso di espansione e valvola di sicurezza di serie
- Possibilità di collegamento di un termostato remoto
- Sistema di pulizia automatica del braciére

Characteristics

- Upper, rear and lateral smoke outlet
- Electronic circulator included
- Expansion vessel and safety valve included
- Possibility to connect a remote thermostat
- Automatic cleaning system of the brazier

Caractéristique

- Sortie des fumées supérieure, latérale et arrière
- Circulateur électronique incluse
- Vase d'expansion et valve de sécurité incluse
- Possibilité de thermostat déporté
- Système autonettoyant du creuset



SIVIGLIA S1 CERAMICA ★★☆☆

Versioni e colori - Versions and colors - Versions et couleurs



KS7250C
Rosso
Red
Rouge

€ 4.968,00



KS7252C
Nero
Black
Noir

€ 4.968,00



KS7253C
Bianco
White
Blanc

€ 4.968,00

Accessori - Accessories - Accessoires



K1093

Modulo Wi-Fi opzionale
Module card Wi Fi available as an option
Module Wi Fi en option

€ 290,00



K1058

Kit sanitario opzionale
Sanitary water kit (available as an option)
Kit eau sanitaire (en option)

€ 400,00



Termostufe hydro ventilate
Hydro-ventilated thermo stoves
Thermopoêles hydro-ventilés



Dati tecnici - Technical data - Données techniques

MISURE (H X L X P) DIMENSIONS (H X L X P) DIMENSIONS (H X L X P)	118 x 98 x 40 cm
POTENZA TERMOCHIMICA THERMO-CHEMICAL POWER PUISSANCE THERMOCHIMIQUE	20,92 kW
POTENZA RESA PER CONVENZIONE ED IRRAGGIAMENTO CONVECTION AND RADIATION POWER OUTPUT PUISSANCE PAR CONVECTION ET IRRADIATION	3,01 kW
POTENZA RESO ALL'ACQUA WATER POWER OUTPUT PUISSANCE A L'EAU	16,98 kW
RENDIMENTO A POTENZA MIN/MAX MIN/MAX EFFICIENCY RENDMENT MIN/MAX	97,39 - 95,57 %
CLASSE DI EFFICIENZA ENERGETICA ENERGY EFFICIENCY CLASS CLASSE D'EFFICACITÀ ENERGETIQUE	A++
CONFORME ALLE NORME IN CONFORMITY TO STANDARD CONFORME AUX RÈGLES	UNI-EN 14785
VOLUME RISCALDABILE MAX MAX HEATABLE VOLUME VOLUME CHAUFFABLE MAX	570 m ³
CONSUMO ORARIO MIN/MAX MIN/MAX CONSUMPTION CONSOMMATION MIN/MAX	1,36 - 4,31 kg/h
ALIMENTAZIONE ELETTRICA TENSION - FREQUENCY TENSION - FRÉQUENCE	230 V - 50 Hz
ASSORBIMENTO ELETTRICO NOMINALE RATED POWER CONSUMPTION CONSOMMATION ÉLECTRIQUE NOMINALE	130 W
CAPENZA SERBATOIO RESERVOIR CAPACITY CAPACITÉ DU RESERVOIR	27 Kg
TIRAGGIO MINIMO MINIMUM DRAUGHT TIRAGE MINIMUM	10-12 Pa
PRESSIONE DI ESERCIZIO WORKING PRESSURE PRESSION	1,5 bar
DIAMETRO SCARICO FUMI SMOKE OUTLET DIAMETER DIAMÈTRE SORTIE DES FUMÉES	80 mm
PESO (CON IMBALLO) WEIGHT (INCLUDING PACKAGE) POIDS (AVEC EMBALLAGE)	ceramica 210 Kg

Caratteristiche particolari

- Scarico fumi superiore, posteriore e laterale
- Circolatore elettronico di serie
- Vaso di espansione e valvola di sicurezza di serie
- Possibilità di collegamento di un termostato remoto
- Sistema di pulizia automatica del braciere

Characteristics

- Upper, rear and lateral smoke outlet
- Electronic circulator included
- Expansion vessel and safety valve included
- Possibility to connect a remote thermostat
- Automatic cleaning system of the brazier

Caractéristique

- Sortie des fumées supérieure, latérale et arrière
- Circulateur électronique incluse
- Vase d'expansion et valve de sécurité incluse
- Possibilité de thermostat déporté
- Systeme autonettoyant du creuset

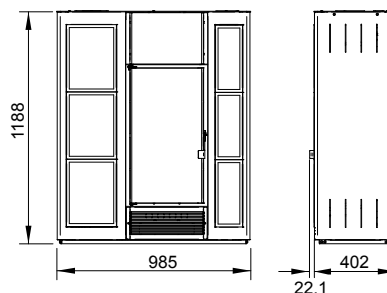



Versioni e colori - Versions and colors - Versions et couleurs



KP4000

Rosso
Red
Rouge

€ 4.350,00



KP4001

Nero
Black
Noir

€ 4.350,00



KP4002

Bianco
White
Blanc

€ 4.350,00

Accessori - Accessories - Accessoires



K1093

Modulo Wi-Fi opzionale
Module card Wi Fi available as an option
Module Wi Fi en option

€ 290,00



K1056

Kit sanitario opzionale
Sanitary water kit (available as an option)
Kit eau sanitaire (en option)

€ 400,00

A+



Dati tecnici - Technical data - Données techniques

MISURE (H X L X P) DIMENSIONS (H X L X P) DIMENSIONS (H X L X P)	116 x 57 x 58 cm
POTENZA TERMOCHIMICA THERMO-CHEMICAL POWER PUISSANCE THERMOCHIMIQUE	20,28 kW
POTENZA RESA PER CONVENZIONE ED IRRAGGIAMENTO CONVECTION AND RADIATION POWER OUTPUT PUISSANCE PAR CONVECTION ET IRRADIATION	2,22 kW
POTENZA RESO ALL'ACQUA WATER POWER OUTPUT PUISSANCE A L'EAU	16,57 kW
RENDIMENTO A POTENZA MIN/MAX MIN/MAX EFFICIENCY RENDIMENT MIN/MAX	95,74 - 92,69 %
CLASSE DI EFFICIENZA ENERGETICA ENERGY EFFICIENCY CLASS CLASSE D'EFFICACITÀ ENERGETIQUE	A+
CONFORME ALLE NORME IN CONFORMITY TO STANDARD CONFORME AUX RÈGLES	UNI-EN 14785
VOLUME RISCALDABILE MAX MAX HEATABLE VOLUME VOLUME CHAUFFABLE MAX	552 m ³
CONSUMO ORARIO MIN/MAX MIN/MAX CONSUMPTION CONSOMMATION MIN/MAX	1,18 - 4,11 kg/h
ALIMENTAZIONE ELETTRICA TENSION - FREQUENCY TENSION - FRÉQUENCE	230 V - 50 Hz
ASSORBIMENTO ELETTRICO NOMINALE RATED POWER CONSUMPTION CONSOMMATION ÉLECTRIQUE NOMINALE	95 W
CAPACITÀ SERBATOIO RESERVOIR CAPACITY CAPACITÉ DU RESERVOIR	30 Kg
TIRAGGIO MINIMO MINIMUM DRAUGHT TIRAGE MINIMUM	10-12 Pa
PRESSIONE DI ESERCIZIO WORKING PRESSURE PRESSION	1,5 bar
DIAMETRO SCARICO FUMI SMOKE OUTLET DIAMETER DIAMÈTRE SORTIE DES FUMÉES	80 mm
PESO (CON IMBALLO) WEIGHT (INCLUDING PACKAGE) POIDS (AVEC EMBALLAGE)	202 Kg

Caratteristiche particolari

- Braciere in ghisa
- Scarico fumi posteriore
- Circulatore elettronico di serie
- Vaso di espansione e valvola di sicurezza di serie
- Possibilità di collegamento di un termostato remoto
- Ventilatori ambiente
- Sistema di pulizia automatica del braciere

Characteristics

- Cast iron brazier
- Rear smoke outlet
- Electronic circulator included
- Expansion vessel and safety valve included
- Possibility to connect a remote thermostat
- Room fans
- Automatic cleaning system of the brazier

Caractéristique

- Creuset en fonte
- Sortie des fumées arrière
- Circulateur électronique incluse
- Vase d'expansion et valve de sécurité incluse
- Possibilité de thermostat déporté
- Ventilateur d'air ambiant
- Systeme autonettoyant du creuset

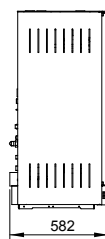
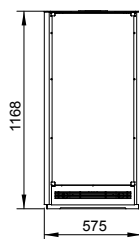

CAPRI ACCAIO ★★★★



Versioni e colori - Versions and colors - Versions et couleurs



KP5000
Rosso
Red
Rouge

€ 5.128,00



KP5001
Bianco
White
Blanc

€ 5.128,00



KP5003
Bronzo
Bronze
Bronze

€ 5.128,00

Accessori - Accessories - Accessoires



K1092

Modulo Wi-Fi opzionale
Module card Wi Fi available as an option
Module Wi Fi en option

€ 330,00



K1057

Kit sanitario opzionale
Sanitary water kit (available as an option)
Kit eau sanitaire (en option)

€ 400,00



Termostufe hydro ventilate
Hydro-ventilated thermo stoves
Thermopoêles hydro-ventilés



Dati tecnici - Technical data - Données techniques

MISURE (H X L X P) DIMENSIONS (H X L X P) DIMENSIONS (H X L X P)	124 x 60 x 62 cm
POTENZA TERMOCHIMICA THERMO-CHEMICAL POWER PUISSANCE THERMOCHIMIQUE	25,12 kW
POTENZA RESA PER CONVEZIONE ED IRRAGGIAMENTO CONVECTION AND RADIATION POWER OUTPUT PUISSANCE PAR CONVECTION ET IRRADIATION	2,79 kW
POTENZA RESO ALL'ACQUA WATER POWER OUTPUT PUISSANCE A L'EAU	20,61 kW
RENDIMENTO A POTENZA MIN/MAX MIN/MAX EFFICIENCY RENDMENT MIN/MAX	96,73 - 93,17 %
CLASSE DI EFFICIENZA ENERGETICA ENERGY EFFICIENCY CLASS CLASSE D'EFFICACITÀ ENERGETIQUE	A+
CONFORME ALLE NORME IN CONFORMITY TO STANDARD CONFORME AUX RÈGLES	UNI-EN 14785
VOLUME RISCALDABILE MAX MAX HEATABLE VOLUME VOLUME CHAUFFABLE MAX	670 m ³
CONSUMO ORARIO MIN/MAX MIN/MAX CONSUMPTION CONSOMMATION MIN/MAX	1,71 - 5,18 kg/h
ALIMENTAZIONE ELETTRICA TENSION - FREQUENCY TENSION - FRÉQUENCE	230 V - 50 Hz
ASSORBIMENTO ELETTRICO NOMINALE RATED POWER CONSUMPTION CONSOMMATION ÉLECTRIQUE NOMINALE	112,6 W
CAPAZITÀ SERBATOIO RESERVOIR CAPACITY CAPACITÉ DU RESERVOIR	27 Kg
TIRAGGIO MINIMO MINIMUM DRAUGHT TIRAGE MINIMUM	10-12 Pa
PRESSIONE DI ESERCIZIO WORKING PRESSURE PRESSION	1,5 bar
DIAMETRO SCARICO FUMI SMOKE OUTLET DIAMETER DIAMÈTRE SORTIE DES FUMÉES	100 mm
PESO (CON IMBALLO) WEIGHT (INCLUDING PACKAGE) POIDS (AVEC EMBALLAGE)	225 Kg

Caratteristiche particolari

- Braciere in ghisa
- Scarico fumi posteriore
- Circulatore elettronico di serie
- Vaso di espansione e valvola di sicurezza di serie
- Possibilità di collegamento di un termostato remoto
- Sistema di pulizia automatica del braciere
- Ventilatori ambiente

Characteristics

- Cast iron brazier
- Rear smoke outlet
- Electronic circulator included
- Expansion vessel and safety valve included
- Possibility to connect a remote thermostat
- Automatic cleaning system of the brazier
- Room fans

Caractéristique

- Creuset en fonte
- Sortie des fumées arrière
- Circulateur électronique incluse
- Vase d'expansion et valve de sécurité incluse
- Possibilité de thermostat déporté
- Système autonettoyant du creuset
- Ventilateur d'air ambient

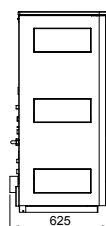
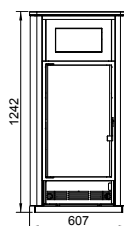

CAPRI VETRO ★★☆☆



Versioni e colori - Versions and colors - Versions et couleurs



KP5090

Vetro
Glass
Verre

€ 5.438,00

Accessori - Accessories - Accessoires



K1092

Modulo Wi-Fi opzionale
Module card Wi Fi available as an option
Module Wi Fi en option

€ 330,00



K1057

Kit sanitario opzionale
Sanitary water kit (available as an option)
Kit eau sanitaire (en option)

€ 400,00

A+



Dati tecnici - Technical data - Données techniques

MISURE (H X L X P) DIMENSIONS (H X L X P) DIMENSIONS (H X L X P)	122 x 60 x 62 cm
POTENZA TERMOCHIMICA THERMO-CHEMICAL POWER PUISSANCE THERMOCHIMIQUE	25,12 kW
POTENZA RESA PER CONVENZIONE ED IRRAGGIAMENTO CONVECTION AND RADIATION POWER OUTPUT PUISSANCE PAR CONVECTION ET IRRADIATION	2,79 kW
POTENZA RESO ALL'ACQUA WATER POWER OUTPUT PUISSANCE A L'EAU	20,61 kW
RENDIMENTO A POTENZA MIN/MAX MIN/MAX EFFICIENCY RENDIMENT MIN/MAX	96,73 - 93,17 %
CLASSE DI EFFICIENZA ENERGETICA ENERGY EFFICIENCY CLASS CLASSE D'EFFICACITÀ ENERGETIQUE	A+
CONFORME ALLE NORME IN CONFORMITY TO STANDARD CONFORME AUX RÈGLES	UNI-EN 14785
VOLUME RISCALDABILE MAX MAX HEATABLE VOLUME VOLUME CHAUFFABLE MAX	670 m ³
CONSUMO ORARIO MIN/MAX MIN/MAX CONSUMPTION CONSOMMATION MIN/MAX	1,71 - 5,18 kg/h
ALIMENTAZIONE ELETTRICA TENSION - FREQUENCY TENSION - FRÉQUENCE	230 V - 50 Hz
ASSORBIMENTO ELETTRICO NOMINALE RATED POWER CONSUMPTION CONSOMMATION ÉLECTRIQUE NOMINALE	112,6 W
CAPAZITÀ SERBATOIO RESERVOIR CAPACITY CAPACITÉ DU RESERVOIR	27 Kg
TIRAGGIO MINIMO MINIMUM DRAUGHT TIRAGE MINIMUM	10-12 Pa
PRESSIONE DI ESERCIZIO WORKING PRESSURE PRESSION	1,5 bar
DIAMETRO SCARICO FUMI SMOKE OUTLET DIAMETER DIAMÈTRE SORTIE DES FUMÉES	100 mm
PESO (CON IMBALLO) WEIGHT (INCLUDING PACKAGE) POIDS (AVEC EMBALLAGE)	225 Kg

Caratteristiche particolari

- Braciere in ghisa
- Scarico fumi posteriore
- Circulatore elettronico di serie
- Vaso di espansione e valvola di sicurezza di serie
- Possibilità di collegamento di un termostato remoto
- Sistema di pulizia automatica del braciere
- Ventilatori ambiente

Characteristics

- Cast iron brazier
- Rear smoke outlet
- Electronic circulator included
- Expansion vessel and safety valve included
- Possibility to connect a remote thermostat
- Automatic cleaning system of the brazier
- Room fans

Caractéristique

- Creuset en fonte
- Sortie des fumées arrière
- Circulateur électronique incluse
- Vase d'expansion et valve de sécurité incluse
- Possibilité de thermostat déporté
- Système autonettoyant du creuset
- Ventilateur d'air ambient

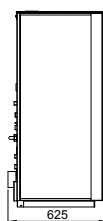
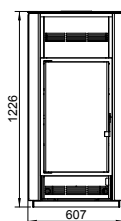



Versioni e colori - Versions and colors - Versions et couleurs



KP5050
Rosso
Red
Rouge

€ 5.827,00



KP5051
Bianco
White
Blanc

€ 5.827,00



KP5053
Effetto legno
Wooden finish
Imitation bois

€ 5.827,00

Accessori - Accessories - Accessoires



K1092
Modulo Wi-Fi opzionale
Module card Wi Fi available as an option
Module Wi Fi en option

€ 330,00



K1057
Kit sanitario opzionale
Sanitary water kit (available as an option)
Kit eau sanitaire (en option)

€ 400,00



Termostufe hydro ventilate
Hydro-ventilated thermo stoves
Thermopoêles hydro-ventilés



Dati tecnici - Technical data - Données techniques

MISURE (H X L X P) DIMENSIONS (H X L X P) DIMENSIONS (H X L X P)	124 x 60 x 62 cm
POTENZA TERMOCHIMICA THERMO-CHEMICAL POWER PUISSANCE THERMOCHIMIQUE	25,12 kW
POTENZA RESA PER CONVEZIONE ED IRRAGGIAMENTO CONVECTION AND RADIATION POWER OUTPUT PUISSANCE PAR CONVECTION ET IRRADIATION	2,79 kW
POTENZA RESO ALL'ACQUA WATER POWER OUTPUT PUISSANCE A L'EAU	20,61 kW
RENDIMENTO A POTENZA MIN/MAX MIN/MAX EFFICIENCY RENDMENT MIN/MAX	96,73 - 93,17 %
CLASSE DI EFFICIENZA ENERGETICA ENERGY EFFICIENCY CLASS CLASSE D'EFFICACITÀ ENERGETIQUE	A+
CONFORME ALLE NORME IN CONFORMITY TO STANDARD CONFORME AUX RÈGLES	UNI-EN 14785
VOLUME RISCALDABILE MAX MAX HEATABLE VOLUME VOLUME CHAUFFABLE MAX	670 m ³
CONSUMO ORARIO MIN/MAX MIN/MAX CONSUMPTION CONSOMMATION MIN/MAX	1,71 - 5,18 kg/h
ALIMENTAZIONE ELETTRICA TENSION - FREQUENCY TENSION - FRÉQUENCE	230 V - 50 Hz
ASSORBIMENTO ELETTRICO NOMINALE RATED POWER CONSUMPTION CONSOMMATION ÉLECTRIQUE NOMINALE	112,6 W
CAPACITÀ SERBATOIO RESERVOIR CAPACITY CAPACITÉ DU RESERVOIR	27 Kg
TIRAGGIO MINIMO MINIMUM DRAUGHT TIRAGE MINIMUM	10-12 Pa
PRESSIONE DI ESERCIZIO WORKING PRESSURE PRESSION	1,5 bar
DIAMETRO SCARICO FUMI SMOKE OUTLET DIAMETER DIAMÈTRE SORTIE DES FUMÉES	100 mm
PESO (CON IMBALLO) WEIGHT (INCLUDING PACKAGE) POIDS (AVEC EMBALLAGE)	225 Kg

Caratteristiche particolari

- Braciere in ghisa
- Scarico fumi posteriore
- Circulatore elettronico di serie
- Vaso di espansione e valvola di sicurezza di serie
- Possibilità di collegamento di un termostato remoto
- Sistema di pulizia automatica del braciere
- Ventilatori ambiente

Characteristics

- Cast iron brazier
- Rear smoke outlet
- Electronic circulator included
- Expansion vessel and safety valve included
- Possibility to connect a remote thermostat
- Automatic cleaning system of the brazier
- Room fans

Caractéristique

- Creuset en fonte
- Sortie des fumées arrière
- Circulateur électronique incluse
- Vase d'expansion et valve de sécurité incluse
- Possibilité de thermostat déporté
- Système autonettoyant du creuset
- Ventilateur d'air ambiant

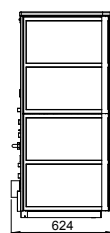
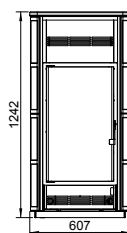

AMALFI ACCIAIO ★★☆☆



Versioni e colori - Versions and colors - Versions et couleurs



KP8000

Rosso
Red
Rouge

€ 5.438,00



KP8001

Bianco
White
Blanc

€ 5.438,00



KP8003

Bronzo
Bronze
Bronze

€ 5.438,00

Accessori - Accessories - Accessoires



K1092

Modulo Wi-Fi opzionale
Module card Wi Fi available as an option
Module Wi Fi en option

€ 330,00



K1057

Kit sanitario opzionale
Sanitary water kit (available as an option)
Kit eau sanitaire (en option)

€ 400,00

A+



Dati tecnici - Technical data - Données techniques

MISURE (H X L X P) DIMENSIONS (H X L X P) DIMENSIONS (H X L X P)	124 x 60 x 63 cm
POTENZA TERMOCHIMICA THERMO-CHEMICAL POWER PUISSANCE THERMOCHIMIQUE	29,95 kW
POTENZA RESA PER CONVENZIONE ED IRRAGGIAMENTO CONVECTION AND RADIATION POWER OUTPUT PUISSANCE PAR CONVECTION ET IRRADIATION	3,16 Kw
POTENZA RESO ALL'ACQUA WATER POWER OUTPUT PUISSANCE A L'EAU	24,64 kW
RENDIMENTO A POTENZA MIN/MAX MIN/MAX EFFICIENCY RENDIMENT MIN/MAX	96,73 - 92,83 %
CLASSE DI EFFICIENZA ENERGETICA ENERGY EFFICIENCY CLASS CLASSE D'EFFICACITÀ ENERGETIQUE	A+
CONFORME ALLE NORME IN CONFORMITY TO STANDARD CONFORME AUX RÈGLES	UNI-EN 14785
VOLUME RISCALDABILE MAX MAX HEATABLE VOLUME VOLUME CHAUFFABLE MAX	796 m ³
CONSUMO ORARIO MIN/MAX MIN/MAX CONSUMPTION CONSOMMATION MIN/MAX	1,71 - 6,17 kg/h
ALIMENTAZIONE ELETTRICA TENSION - FREQUENCY TENSION - FRÉQUENCE	230 V - 50 Hz
ASSORBIMENTO ELETTRICO NOMINALE RATED POWER CONSUMPTION CONSOMMATION ÉLECTRIQUE NOMINALE	138,6 W
CAPAZITÀ SERBATOIO RESERVOIR CAPACITY CAPACITÉ DU RESERVOIR	27 Kg
TIRAGGIO MINIMO MINIMUM DRAUGHT TIRAGE MINIMUM	10-12 Pa
PRESSIONE DI ESERCIZIO WORKING PRESSURE PRESSION	1,5 bar
DIAMETRO SCARICO FUMI SMOKE OUTLET DIAMETER DIAMÈTRE SORTIE DES FUMÉES	100 mm
PESO (CON IMBALLO) WEIGHT (INCLUDING PACKAGE) POIDS (AVEC EMBALLAGE)	225 Kg

Caratteristiche particolari

- Braciere in ghisa
- Scarico fumi posteriore
- Circulatore elettronico di serie
- Vaso di espansione e valvola di sicurezza di serie
- Possibilità di collegamento di un termostato remoto
- Sistema di pulizia automatica del braciere
- Ventilatori ambiente

Characteristics

- Cast iron brazier
- Rear smoke outlet
- Electronic circulator included
- Expansion vessel and safety valve included
- Possibility to connect a remote thermostat
- Automatic cleaning system of the brazier
- Room fans

Caractéristique

- Creuset en fonte
- Sortie des fumées arrière
- Circulateur électronique incluse
- Vase d'expansion et valve de sécurité incluse
- Possibilité de thermostat déporté
- Système autonettoyant du creuset
- Ventilateur d'air ambiant

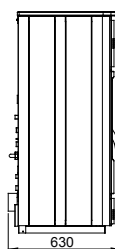
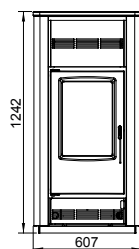



Versioni e colori - Versions and colors - Versions et couleurs



KP8050

Rosso
Red
Rouge

€ 6.102,00



KP8051

Effetto legno
Wooden finish
Imitation bois

€ 6.102,00



KP8052

Bianco
White
Blanc

€ 6.102,00

Accessori - Accessories - Accessoires



K1092

Modulo Wi-Fi opzionale
Module card Wi Fi available as an option
Module Wi Fi en option

€ 330,00



K1057

Kit sanitario opzionale
Sanitary water kit (available as an option)
Kit eau sanitaire (en option)

€ 400,00



Termostufe hydro ventilate
Hydro-ventilated thermo stoves
Thermopoêles hydro-ventilés

A+



Dati tecnici - Technical data - Données techniques

MISURE (H X L X P) DIMENSIONS (H X L X P) DIMENSIONS (H X L X P)	124 x 60 x 63 cm
POTENZA TERMOCHIMICA THERMO-CHEMICAL POWER PUISSANCE THERMOCHIMIQUE	29,95 kW
POTENZA RESA PER CONVEZIONE ED IRRAGGIAMENTO CONVECTION AND RADIATION POWER OUTPUT PUISSANCE PAR CONVECTION ET IRRADIATION	3,16 Kw
POTENZA RESO ALL'ACQUA WATER POWER OUTPUT PUISSANCE A L'EAU	24,64 kW
RENDIMENTO A POTENZA MIN/MAX MIN/MAX EFFICIENCY RENDEMENT MIN/MAX	96,73 - 92,83 %
CLASSE DI EFFICIENZA ENERGETICA ENERGY EFFICIENCY CLASS CLASSE D'EFFICACITE ENERGETIQUE	A+
CONFORME ALLE NORME IN CONFORMITY TO STANDARD CONFORME AUX REGLES	UNI-EN 14785
VOLUME RISCALDABILE MAX MAX HEATABLE VOLUME VOLUME CHAUFFABLE MAX	796 m ³
CONSUMO ORARIO MIN/MAX MIN/MAX CONSUMPTION CONSOMMATION MIN/MAX	1,71 - 6,17 kg/h
ALIMENTAZIONE ELETTRICA TENSION - FREQUENCY TENSION - FREQUENCE	230 V - 50 Hz
ASSORBIMENTO ELETTRICO NOMINALE RATED POWER CONSUMPTION CONSOMMATION ELECTRIQUE NOMINALE	138,6 W
CAPAZITA' SERBATOIO RESERVOIR CAPACITY CAPACITE DU RESERVOIR	27 Kg
TIRAGGIO MINIMO MINIMUM DRAUGHT TIRAGE MINIMUM	10-12 Pa
PRESSIONE DI ESERCIZIO WORKING PRESSURE PRESSION	1,5 bar
DIAMETRO SCARICO FUMI SMOKE OUTLET DIAMETER DIAMETRE SORTIE DES FUMÉES	100 mm
PESO (CON IMBALLO) WEIGHT (INCLUDING PACKAGE) POIDS (AVEC EMBALLAGE)	252 Kg

Caratteristiche particolari

- Braciere in ghisa
- Scarico fumi posteriore
- Circulatore elettronico di serie
- Vaso di espansione e valvola di sicurezza di serie
- Possibilità di collegamento di un termostato remoto
- Sistema di pulizia automatica del braciere
- Ventilatori ambiente

Characteristics

- Cast iron brazier
- Rear smoke outlet
- Electronic circulator included
- Expansion vessel and safety valve included
- Possibility to connect a remote thermostat
- Automatic cleaning system of the brazier
- Room fans

Caractéristique

- Creuset en fonte
- Sortie des fumées arrière
- Circulateur électronique incluse
- Vase d'expansion et valve de sécurité incluse
- Possibilité de thermostat déporté
- Systeme autonettoyant du creuset
- Ventilateur d'air ambient

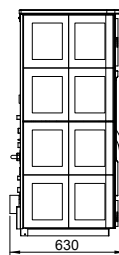
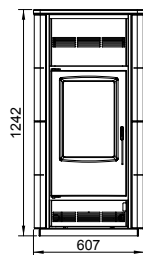

MADRID ACCIAIO ★ ★ ★



Versioni e colori - Versions and colors - Versions et couleurs



H1000C

Nero
Black
Noir

€ 4.064,00

Accessori - Accessories - Accessoires



H1050

Kit struttura portainserto
Support
Support

€ 190,00

A+



Dati tecnici - Technical data - Données techniques

MISURE (H X L X P)
DIMENSIONS (H X L X P)
DIMENSIONS (H X L X P) 78 x 82 x 73 cm

POTENZA TERMOCHIMICA
THERMO-CHEMICAL POWER
PUISSANCE THERMOCHIMIQUE 19,34 kW

POTENZA RESA PER CONVEZIONE ED IRRAGGIAMENTO
CONVECTION AND RADIATION POWER OUTPUT
PUISSANCE PAR CONVECTION ET IRRADIATION 2,67 kW

POTENZA RESO ALL'ACQUA
WATER POWER OUTPUT
PUISSANCE A L'EAU 14,68 kW

RENDIMENTO A POTENZA MIN/MAX
MIN/MAX EFFICIENCY
RENDIMENT MIN/MAX 94,88 - 89,70 %

CLASSE DI EFFICIENZA ENERGETICA
ENERGY EFFICIENCY CLASS
CLASSE D'EFFICACITÀ ENERGETIQUE A+

CONFORME ALLE NORME
IN CONFORMITY TO STANDARD
CONFORME AUX RÈGLES UNI-EN 14785

VOLUME RISCALDABILE MAX
MAX HEATABLE VOLUME
VOLUME CHAUFFABLE MAX 497 m³

CONSUMO ORARIO MIN/MAX
MIN/MAX CONSUMPTION
CONSOMMATION MIN/MAX 0,98 - 3,95 kg/h

ALIMENTAZIONE ELETTRICA
TENSION - FREQUENCY
TENSION - FRÉQUENCE 230 V - 50 Hz

ASSORBIMENTO ELETTRICO NOMINALE
RATED POWER CONSUMPTION
CONSOMMATION ÉLECTRIQUE NOMINALE 95 W

CAPACITÀ SERBATOIO
RESERVOIR CAPACITY
CAPACITÉ DU RESERVOIR 32 Kg

TIRAGGIO MINIMO
MINIMUM DRAUGHT
TIRAGE MINIMUM 10-12 Pa

PRESSIONE DI ESERCIZIO
WORKING PRESSURE
PRESSION 1,5 bar

DIAMETRO SCARICO FUMI
SMOKE OUTLET DIAMETER
DIAMÈTRE SORTIE DES FUMÉES 100 mm

PESO (CON IMBALLO)
WEIGHT (INCLUDING PACKAGE)
POIDS (AVEC EMBALLAGE) 150 Kg

Caratteristiche particolari

- Estraibile (manutenzione facilitata)
- Caricamento pellet attraverso bocchetta rifornimento orientabile
- Circulatore elettronico di serie
- Vaso di espansione e valvola di sicurezza di serie
- Possibilità di collegamento di un termostato remoto

Characteristics

- Extractable (for easier maintenance)
- Positionable resupply door
- Electronic circulator included
- Expansion vessel and safety valve included
- Possibility to connect a remote thermostat

Caractéristique

- Extractible (manutenzione facile)
- Rosace installabile in diverse posizioni
- Circulatore elettronico incluso
- Vaso d'espansione e valvola di sicurezza inclusa
- Possibilità di termostato deporté

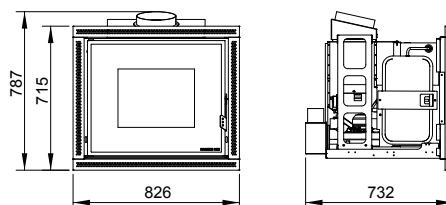

- 
- CALDAIE PELLET
 - PELLET BOILERS
 - CHAUDIÈRES À GRANULÉS

TERMORODI 22A ★★★★



Serbatoio supplementare 200 Kg
Additional tank 200 Kg
Réservoir supplémentaire 200 Kg

Versioni e colori - Versions and colors - Versions et couleurs

KB2200PL Grigio/Nero - Grey/Black - Gris/Noir

€ 5.552,00

Accessori - Accessories - Accessoires

K1080	Sensore livello pellet - Pellet level sensor - Capteur de niveau pour le pellet	€ 80,00
K1035	Kit controllo remoto K100LCD - Remote control kit K100LCD - Kit de contrôle à distance K100LCD	€ 240,00
AF8000	Valvola anticondensa - Anti-condensation valve - Soupape anticondensation	€ 180,00
K1090	Modem GSM - GSM Modem - Modem GSM	€ 475,00
K1092	Dispositivo controllo remoto Wi-Fi - Module remote control Wi Fi (available as an option) - Dispositif de contrôle à distance Wi Fi	€ 330,00
K1094	Kit controllo remoto K400 - Remote control kit K400 - Kit de contrôle à distance K400	€ 480,00
K1095	Kit controllo remoto K700 - Remote control kit K700 - Kit de contrôle à distance K700	€ 560,00
K9997	Serbatoio supplementare 200 Kg - Additional tank 200 Kg - Réservoir supplémentaire 200 Kg	€ 1.477,00



Dati tecnici - Technical data - Données techniques

MISURE (H X L X P) DIMENSIONS (H X L X P) DIMENSIONS (H X L X P)	137 x 88 x 66 cm
POTENZA TERMOCHIMICA THERMO-CHEMICAL POWER PUISSANCE THERMOCHIMIQUE	24,09 kW
POTENZA RESO ALL'ACQUA WATER POWER OUTPUT PUISSANCE À L'EAU	22,35 kW
RENDIMENTO A POTENZA MIN/MAX MIN/MAX EFFICIENCY RENDIMENT MIN/MAX	88,18 - 92,74 %
CLASSE DI EFFICIENZA ENERGETICA ENERGY EFFICIENCY CLASS CLASSE D'EFFICACITÉ ÉNERGÉTIQUE	A+
CONFORME ALLE NORME IN CONFORMITY TO STANDARD CONFORME AUX RÈGLES	UNI-EN 303-5
VOLUME RISCALDABILE MAX MAX HEATABLE VOLUME VOLUME CHAUFFABLE MAX	690 m ³
CONSUMO ORARIO MIN/MAX MIN/MAX CONSUMPTION CONSOMMATION MIN/MAX	1,29 - 4,97 kg/h
ALIMENTAZIONE ELETTRICA TENSION - FREQUENCY TENSION - FRÉQUENCE	230 V - 50 Hz
ASSORBIMENTO ELETTRICO NOMINALE RATED POWER CONSUMPTION CONSOMMATION ÉLECTRIQUE NOMINALE	104 W
CAPENZA SERBATOIO RESERVOIR CAPACITY CAPACITÉ DU RESERVOIR	50 Kg
TIRAGGIO MINIMO MINIMUM DRAUGHT TIRAGE MINIMUM	10-12 Pa
PRESSIONE DI ESERCIZIO WORKING PRESSURE PRESSION	1,5 bar
DIAMETRO SCARICO FUMI SMOKE OUTLET DIAMETER DIAMÈTRE SORTIE DES FUMÉES	100 mm
PESO (CON IMBALLO) WEIGHT (INCLUDING PACKAGE) POIDS (AVEC EMBALLAGE)	310 Kg

Caratteristiche particolari

- Sistema di pulizia automatica del braciere
- Kit sanitario di serie
- Circulatore elettronico ad alta efficienza di serie
- Pulizia turbolatori automatica
- Alta efficienza
- Scheda elettronica Multisystem

Characteristics

- Automatic cleaning system of the brazier
- Sanitary water kit included
- High efficiency electronic circulator included
- Automatic turbolator cleaning
- High efficiency
- Multisystem el. Card

Caractéristique

- Systeme autonettoyant du creuset
- Kit eau sanitaire (incluse)
- Circulateur électronique à grandes performances incluse
- Nettoyage automatique des turbulateurs
- Grandes performances
- Carte él. Multisystem

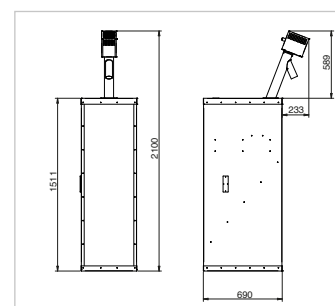
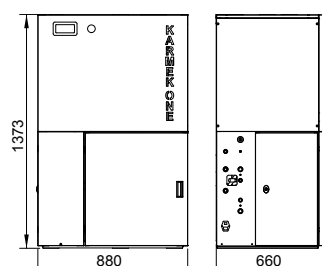

TERMORODI 24 ★★☆☆



Serbatoio supplementare 200 Kg
Additional tank 200 Kg
Réservoir supplémentaire 200 Kg



Versioni e colori - Versions and colors - Versions et couleurs

KB2400PL Grigio/Nero - Grey/Black - Gris/Noir

€ 6.617,00

Accessori - Accessories - Accessoires

K1080	Sensore livello pellet - Pellet level sensor - Capteur de niveau pour le pellet	€ 80,00
K1035	Kit controllo remoto K100LCD - Remote control kit K100LCD - Kit de contrôle à distance K100LCD	€ 240,00
AF8000	Valvola anticondensa - Anti-condensation valve - Soupape anticondensation	€ 180,00
K1090	Modem GSM - GSM Modem - Modem GSM	€ 475,00
K1092	Dispositivo controllo remoto Wi-Fi - Module remote control Wi Fi (available as an option) - Dispositif de contrôle à distance Wi Fi	€ 330,00
K1094	Kit controllo remoto K400 - Remote control kit K400 - Kit de contrôle à distance K400	€ 480,00
K1095	Kit controllo remoto K700 - Remote control kit K700 - Kit de contrôle à distance K700	€ 560,00
K9998	Serbatoio supplementare 200 Kg - Additional tank 200 Kg - Réservoir supplémentaire 200 Kg	€ 1.477,00



Caldia pellet
Pellet boilers
Chaudières à granulés



Dati tecnici - Technical data - Données techniques

MISURE (H X L X P) DIMENSIONS (H X L X P) DIMENSIONS (H X L X P)	154 x 96 x 70 cm
POTENZA TERMOCHIMICA THERMO-CHEMICAL POWER PUISSANCE THERMOCHIMIQUE	27,43 kW
POTENZA RESO ALL'ACQUA WATER POWER OUTPUT PUISSANCE À L'EAU	25,13 kW
RENDIMENTO A POTENZA MIN/MAX MIN/MAX EFFICIENCY RENDIMENT MIN/MAX	88,62 - 91,63 %
CLASSE DI EFFICIENZA ENERGETICA ENERGY EFFICIENCY CLASS CLASSE D'EFFICACITÉ ÉNERGÉTIQUE	A+
CONFORME ALLE NORME IN CONFORMITY TO STANDARD CONFORME AUX RÈGLES	UNI-EN 303-5
VOLUME RISCALDABILE MAX MAX HEATABLE VOLUME VOLUME CHAUFFABLE MAX	720 m ³
CONSUMO ORARIO MIN/MAX MIN/MAX CONSUMPTION CONSOMMATION MIN/MAX	1,66 - 5,68 kg/h
ALIMENTAZIONE ELETTRICA TENSION - FREQUENCY TENSION - FRÉQUENCE	230 V - 50 Hz
ASSORBIMENTO ELETTRICO NOMINALE RATED POWER CONSUMPTION CONSOMMATION ÉLECTRIQUE NOMINALE	99 W
CAPAZITÀ SERBATOIO RESERVOIR CAPACITY CAPACITÉ DU RESERVOIR	70 Kg
TIRAGGIO MINIMO MINIMUM DRAUGHT TIRAGE MINIMUM	10-12 Pa
PRESSIONE DI ESERCIZIO WORKING PRESSURE PRESSION	1,5 bar
DIAMETRO SCARICO FUMI SMOKE OUTLET DIAMETER DIAMÈTRE SORTIE DES FUMÉES	100 mm
PESO (CON IMBALLO) WEIGHT (INCLUDING PACKAGE) POIDS (AVEC EMBALLAGE)	410 Kg

Caratteristiche particolari

- Sistema di pulizia automatica del braciére
- Kit sanitario di serie
- Circulatore elettronico ad alta efficienza di serie
- Pulizia turbolatori automatica
- Alta efficienza
- Scheda elettronica Multisystem

Characteristics

- Automatic cleaning system of the brazier
- Sanitary water kit included
- High efficiency electronic circulator included
- Automatic turbolator cleaning
- High efficiency
- Multisystem el. Card

Caractéristique

- Systeme autonettoyant du creuset
- Kit eau sanitaire (incluse)
- Circulateur électronique à grandes performances incluse
- Nettoyage automatique des turbulateurs
- Grandes performances
- Carte él. Multisystem

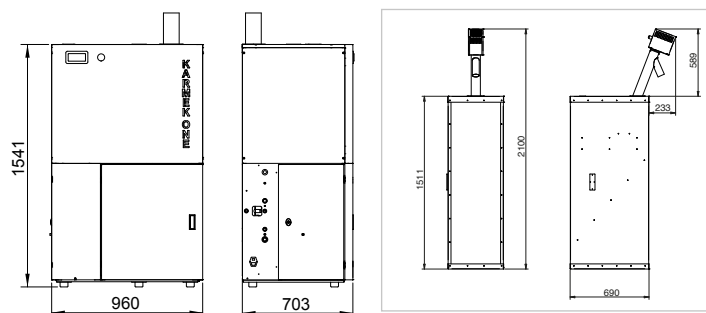

TERMORODI 34 ★★☆☆



Serbatoio supplementare 200 Kg
Additional tank 200 Kg
Réservoir supplémentaire 200 Kg



Versioni e colori - Versions and colors - Versions et couleurs

KB3400PL Grigio/Nero - Grey/Black - Gris/Noir

€ 6.972,00

Accessori - Accessories - Accessoires

K1080	Sensore livello pellet - Pellet level sensor - Capteur de niveau pour le pellet	€ 80,00
K1035	Kit controllo remoto K100LCD - Remote control kit K100LCD - Kit de contrôle à distance K100LCD	€ 240,00
AF8000	Valvola anticondensa - Anti-condensation valve - Soupape anticondensation	€ 180,00
K1090	Modem GSM - GSM Modem - Modem GSM	€ 475,00
K1092	Dispositivo controllo remoto Wi-Fi - Module remote control Wi Fi (available as an option) - Dispositif de contrôle à distance Wi Fi	€ 330,00
K1094	Kit controllo remoto K400 - Remote control kit K400 - Kit de contrôle à distance K400	€ 480,00
K1095	Kit controllo remoto K700 - Remote control kit K700 - Kit de contrôle à distance K700	€ 560,00
K9998	Serbatoio supplementare 200 Kg - Additional tank 200 Kg - Réservoir supplémentaire 200 Kg	€ 1.477,00



Dati tecnici - Technical data - Données techniques

MISURE (H X L X P) DIMENSIONS (H X L X P) DIMENSIONS (H X L X P)	154 x 96 x 70 cm
POTENZA TERMOCHIMICA THERMO-CHEMICAL POWER PUISSANCE THERMOCHIMIQUE	33,44 kW
POTENZA RESO ALL'ACQUA WATER POWER OUTPUT PUISSANCE À L'EAU	30,80 kW
RENDIMENTO A POTENZA MIN/MAX MIN/MAX EFFICIENCY RENDIMENT MIN/MAX	88,62 - 92,12 %
CLASSE DI EFFICIENZA ENERGETICA ENERGY EFFICIENCY CLASS CLASSE D'EFFICACITÉ ÉNERGÉTIQUE	A+
CONFORME ALLE NORME IN CONFORMITY TO STANDARD CONFORME AUX RÈGLES	UNI-EN 303-5
VOLUME RISCALDABILE MAX MAX HEATABLE VOLUME VOLUME CHAUFFABLE MAX	882 m ³
CONSUMO ORARIO MIN/MAX MIN/MAX CONSUMPTION CONSOMMATION MIN/MAX	1,66 - 6,93 kg/h
ALIMENTAZIONE ELETTRICA TENSION - FREQUENCY TENSION - FRÉQUENCE	230 V - 50 Hz
ASSORBIMENTO ELETTRICO NOMINALE RATED POWER CONSUMPTION CONSOMMATION ÉLECTRIQUE NOMINALE	109 W
CAPAZITÀ SERBATOIO RESERVOIR CAPACITY CAPACITÉ DU RESERVOIR	70 Kg
TIRAGGIO MINIMO MINIMUM DRAUGHT TIRAGE MINIMUM	10-12 Pa
PRESSIONE DI ESERCIZIO WORKING PRESSURE PRESSION	1,5 bar
DIAMETRO SCARICO FUMI SMOKE OUTLET DIAMETER DIAMÈTRE SORTIE DES FUMÉES	100 mm
PESO (CON IMBALLO) WEIGHT (INCLUDING PACKAGE) POIDS (AVEC EMBALLAGE)	410 Kg

Caratteristiche particolari

- Sistema di pulizia automatica del braciere
- Kit sanitario di serie
- Circulatore elettronico ad alta efficienza di serie
- Pulizia turbolatori automatica
- Alta efficienza
- Scheda elettronica Multisystem

Characteristics

- Automatic cleaning system of the brazier
- Sanitary water kit included
- High efficiency electronic circulator included
- Automatic turbolator cleaning
- High efficiency
- Multisystem el. Card

Caractéristique

- Système autonettoyant du creuset
- Kit eau sanitaire (incluse)
- Circulateur électronique à grandes performances incluse
- Nettoyage automatique des turbulateurs
- Grandes performances
- Carte él. Multisystem

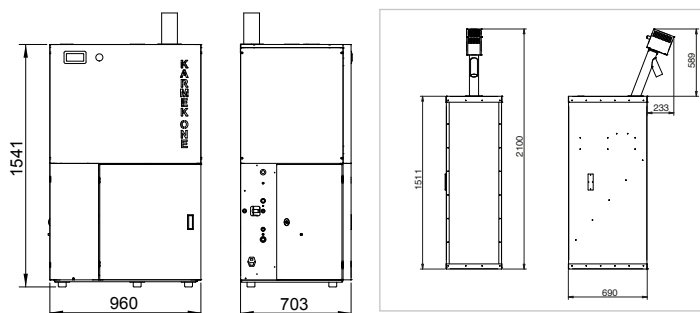



- ACCESSORI
- ACCESSORIES
- ACCESSOIRES

TUBI MONOPARETE PER STUFE A PELLETT











spessore 1,2mm | verniciatura silionica a liquido | per uso interno

SINGLE WALL FLUE PIPES FOR PELLETT STOVES

thickness 1,2mm - silicone liquid paint - for internal use

TUYAUX SIMPLE PAROI POUR POÊLES À PELLETT

épaisseur de 1,2mm - peinture à base de silicone - pour usage interne

Immagine Photo Genre	Descrizione Description Détails	Diametro Diameter Diamètre (mm)	Codice Code Code	Prezzo Price Prix
	Tubo lineare lunghezza 1M Linear pipe L= 1M Tuyau droit de 1M	80	AF1000	€ 59,00
		100	AF2000	€ 67,00
	Tubo lineare lunghezza 50 Cm Linear pipe L= 50 Cm Tuyau droit de 50 Cm	80	AF1100	€ 48,00
		100	AF2100	€ 53,00
	Tubo lineare lunghezza 25 Cm Linear pipe L= 25 Cm Tuyau droit de 25 Cm	80	AF1200	€ 39,00
		100	AF2200	€ 42,00
	Raccordo a "T" "T" pipe fitting Raccord en "T"	80	AF1300	€ 85,00
		100	AF2300	€ 93,00
	Raccordo a "T" ridotto Reduced "T" pipe fitting Raccord en "T" avec réduction	100->80	AF1350	€ 110,00
	Riduzione 80f-100m 80f-100m adaptor Réduction 80f-100m	100->80	AF1400	€ 42,00
	Manicotto f-f F-F pipe fitting Manchon f-f	80	AF1800	€ 37,00
		100	AF2800	€ 42,00
	Curva 90° 90° bent pipe Coude 90°	80	AF1500	€ 70,00
		100	AF2500	€ 78,00
	Curva 45° 45° bent pipe Coude 45°	80	AF1550	€ 66,00
		100	AF2550	€ 69,00
	Rosone Ring Rosace	80	AF1700	€ 20,00
		100	AF2690	€ 24,00
	Fascetta Support pipe clip Collier	80	AF1750	€ 22,00
		100	AF2750	€ 24,00
	Raccordo a T f-f lunghezza 220mm F F T pipe fitting L=220mm Raccord en T f-f longueur 220mm	80	AF1370	€ 85,00
	Terminale Ending caps Terminal	80	AF1600	€ 55,00
		100	AF2600	€ 58,00

Accessori









accessori arredamento | consumabili | strumentazione | termostati

Accessories

furniture accessories - consumables

Accessoires

accessoires d'ameublement - consommables

Immagine Photo Genre	Descrizione Description Détails	Codice Code Code	Prezzo Price Prix
	Vernice spray silconica Silicone spray paint Peinture en aerosol à base de silicone	AF3000 Grigio AF3000 Nero	€ 27,00
	Piastra salvapavimento Floor protection plate Plaque de protection du sol 60 x70 Cm	AF4000	€ 59,00
	Piastra salvapavimento Floor protection plate Plaque de protection du sol 100 x100 Cm	AF4100	€ 87,00
	Piastra salvapavimento Floor protection plate Plaque de protection du sol 100 x 40 Cm	AF4400	€ 60,00
	Piastra salvapavimento Floor protection plate Plaque de protection du sol 80 x 90 Cm	AF4200	€ 67,00
	Piastra salvapavimento Floor protection plate Plaque de protection du sol 90 x 100 Cm	AF4300	€ 75,00
	Silicone alta temperatura High temperature silicone Silicone haute temperature	AF3050	€ 21,00
	Misuratore tiraggio Air drought meter Instrument de mesure du tirage	K1000	€ 605,00
	Aspiracenera Ash vacuum cleaner Aspirateur des ceindres	AF4500	€ 78,00

E' ARRIVATA LA NOSTRA NUOVA APP

KARMEK WiFi



Facile ed intuitiva, la nostra applicazione, ti consente di programmare e gestire le stufe Karmek One direttamente dal tuo smartphone.



OUR NEW APP HAS ARRIVED

KARMEK WiFi

Easy and intuitive, our application allows you to program and manage karmek one stoves directly from your smartphone

NOTRE NOUVELLE APPLICATION EST ARRIVÉE

KARMEK WiFi

Facile et intuitive, notre application vous permet de programmer et de gérer karmek un poêles directement à partir de votre smartphone

La nostra App è disponibile per Android e iOS
Our App is available for Android and iOS
Notre application est disponible pour Android et iOS



Condizioni generali di fornitura Karmek One S.r.l.

Le condizioni generali sotto riportate disciplinano i rapporti contrattuali di fornitura di Karmek One S.r.l. con la propria clientela, ai quali viene data attuazione attraverso singoli ordini.

1. Listino - Il presente listino di vendita viene riservato esclusivamente ai rivenditori degli articoli Karmek One. In alcun caso, esso può costituire offerta diretta di Karmek One al pubblico, anche se i prezzi ivi indicati si riferiscono comunque a prezzi consigliati al pubblico.
2. Ordini - Gli ordini, anche negoziati o proposti, che pervengono a Karmek One si intendono definitivi solo se espressamente da questa accettati ed ulteriormente confermati dal Cliente qualora Karmek One abbia apportato modifiche all'ordine ricevuto. L'ordine dovrà essere completo in tutte le sue parti: descrizione, codice, ecc.
3. Proprietà intellettuali ed industriali - Tutti gli stampati (listino, depliant, cataloghi e documenti simili) relativi ai prodotti sono di proprietà esclusiva di Karmek One. Sono vietate la riproduzione, anche parziale del listino, depliant, cataloghi o altri documenti simili, nonché la pubblicità dei prodotti, se non preventivamente autorizzata.
- 3.1 Il marchio "Karmek One" è un marchio registrato. Karmek One S.r.l. diffida l'uso non autorizzato del proprio marchio, e/o di altri marchi, denominazioni e dei modelli e disegni relativi ai propri prodotti. In particolare, è fatto assoluto divieto al Cliente di ripro-durre totalmente e/o parzialmente modelli relativi ai prodotti acquistati o presi in visione. E' fatto altresì assoluto divieto di comunicare notizie ed informazioni che consentano la riproduzione dei modelli stessi.
4. Prezzi - Se non diversamente stabilito, prezzi indicati nel presente listino si intendono per merce imballata secondo gli usi del settore in relazione al mezzo di trasporto pattuito.
- 4.1 I prezzi contenuti nel listino non potranno mai considerarsi vincolanti; Karmek One potrà infatti modificare i prezzi in qualsiasi momento, con congruo preavviso.
5. Articoli fuori produzione - Karmek One si riserva la facoltà di eliminare, in qualsiasi momento, dalla produzione articoli presenti nel listino o nei cataloghi, dandone adeguata informazione al Cliente.
6. Conformità dei prodotti. Migliorie e modifiche - Rispetto ai dati forniti nel presente listino ovvero in depliant, cataloghi o in documenti simili, Karmek One si riserva il diritto di apportare ai propri prodotti tutte le migliorie e modifiche, anche estetiche, ritenute opportune o necessarie, senza che per questo il Cliente possa sollevare contestazioni o abbia il diritto di risolvere eventuali ordini in corso e/o pretendere indennizzi.
7. Trasporto della merce - La merce viaggia a rischio e pericolo del Cliente anche se spedita in porto franco e qualunque sia il mezzo e la forma in cui è effettuato il trasporto. Karmek One decadrà da ogni eventuale responsabilità con la consegna della merce al primo vettore: eventuali reclami per rotture, deterioramenti, manomissioni o mancanze dovranno essere denunciati a Karmek One nei termini di legge previsti.
- 7.1 Spese per giacenze - Le spese per giacenze presso i corrieri in caso di invio merce su indirizzi diversi dal cliente finale verranno addebitate al cliente alla spedizione successiva, (mediante avviso alla conferma ordine).
8. Termini di consegna - I termini di consegna si intendono computati in giorni lavorativi e decorrono dalla data di conferma dell'ordine.
- 8.1 Salvo differente accordo, i termini di consegna previsti negli ordini sono puramente indicativi e non essenziali; eventuali ritardi nella consegna non potranno dare diritto ad indennizzi e/o risarcimenti di alcun genere.
- 8.2 Eventuali variazioni richieste in fase di produzione sollevano comunque Karmek One dal rispetto dei termini concordati.
9. Contestazioni - La merce deve essere verificata e controllata all'arrivo per la sua conformità all'ordine. Discordanze eventuali, riguardanti la quantità, la specie o il tipo dei prodotti forniti, dovranno essere sempre segnalate per iscritto, anche tramite fax, nel termine massimo di 7 (sette) giorni dal ricevimento, citando tutti gli estremi per un immediato controllo. Trascorso tale termine, i prodotti verranno considerati a tutti gli effetti accettati.
- 9.1 Le contestazioni non comporteranno la risoluzione del singolo ordine, bensì, a discrezione di Karmek One, la riparazione o sostituzione gratuita dei prodotti risultati difettosi, salvo diversa decisione dovuta a ragioni obiettive di impossibilità di adottare uno dei rimedi sopra previsti. Fatti salvi i casi di dolo o colpa grave, quanto sopra disposto esclude ogni altra responsabilità di Karmek One comunque originata dai prodotti forniti o dalla loro rivendita. In particolare, non potranno essere pretesi risarcimenti e/o indennizzi per danni, diretti o indiretti, di qualsiasi natura derivanti dal mancato o limitato utilizzo dei prodotti.
- 9.2 La responsabilità di Karmek One non opererà ove si siano riscontrate incurie, manomissioni, negligenze nell'installazione od installazione compiute in ambienti non conformi.
10. Pagamenti - I pagamenti devono essere compiuti esclusivamente a Karmek One alle condizioni convenute.
- 10.1 E' inteso che eventuali reclami o contestazioni non danno diritto al Cliente di sospendere o comunque ritardare i pagamenti dei prodotti oggetto di contestazione, né tanto meno, di altre forniture. Più in generale, nessuna azione od eccezione potrà essere svolta od opposta dal Cliente se non dopo l'integrale pagamento dei prodotti per i quali tale contestazione od eccezione si intende svolgere.
- 10.2 Il Cliente non è autorizzato ad effettuare alcuna deduzione dal prezzo pattuito (ad es. in caso di pretesi difetti dei prodotti), se non previamente stabilito per iscritto con Karmek One.
- 10.3 In caso di ritardato pagamento alle scadenze pattuite verranno automaticamente addebitati al Cliente, senza alcuna formale diffida, gli interessi di mora calcolati secondo il tasso indicato all'art. 5 del D.lg. 9 ottobre 2002 n. 231 (di recepimento della direttiva comunitaria 2000/35/CE), comprensivo della maggiorazione ivi prevista (saggio di interesse applicato dalla Banca centrale europea alle sue principali operazioni di rifinanziamento, maggiorato di 7 punti percentuali).
- 10.4 Resta convenuto che i prodotti consegnati restano di proprietà di Karmek One fino a quando non sia pervenuto a quest'ultima il completo loro pagamento.
11. Resi di merce - Non si accettano resi di merce se non con l'espressa autorizzazione in forma scritta di Karmek One. I resi devono comunque essere integri (non smontati), imballati (possibilmente nella confezione originale) e accompagnati da bolla di reso, assumendosene il cliente tutti i costi e rischi.
12. Sospensione o annullamento degli ordini - Qualora non fosse rispettata, anche solo in parte, una delle condizioni generali stabilite per la fornitura, come pure in caso di constatata difficoltà nei pagamenti ovvero venissero a mancare o diminuissero le garanzie di solvibilità o, più in generale, la capacità economica del Cliente, è facoltà di Karmek One di sospendere o annullare gli ordini in corso, ovvero di subordinare la consegna dei prodotti alla prestazione di adeguate garanzie di pagamento.
13. Risoluzione delle controversie - Per tutte le controversie derivanti dall'esecuzione e interpretazione dei singoli ordini, oltre che delle presenti condizioni generali, viene riconosciuta la competenza esclusiva del Foro di Treviso.
- 13.1 Tuttavia, in deroga a quanto stabilito sopra, Karmek One ha comunque la facoltà di portare la controversia davanti al giudice competente presso la sede del Cliente.
14. Privacy - Ai sensi e per gli effetti dell'art. 13 del D.Lgs. 196/2003, i dati personali anagrafici e fiscali relativi alle parti contrattuali verranno da queste reciprocamente trattati, in formato elettronico o cartaceo, per consentire una efficace gestione del rapporto commerciale, anche ai fini della tutela del credito. Fatte salve le comunicazioni previste da obblighi di legge, i dati potranno essere da ciascuna di esse comunicati a soggetti quali: istituti di credito, consulenti e professionisti, compagnie assicurative, aziende che operano nel settore dei trasporti, ecc.

Karmek One S.r.l.



MADE IN ITALY

KARMEK ONE Srl

Via Maggior Piovesana, 204
31015 Conegliano TV
Tel. 0438.1883101
Fax 0438.1883103

email: info@karmek.it
www.karmek.it